

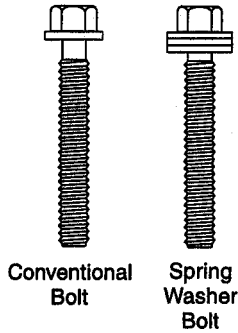

FEL-PRO INSTALLATION TIPS

INTAKE MANIFOLD GASKET



The gasket(s) included in this set will function with manifolds having either "Conventional" or "Spring Washer" style bolts.

Conventional bolts - Do Not torque beyond 22 ft. lbs.

Spring Washer bolts - Do Not torque beyond 12 ft. lbs.

RESTRICTED PORT GASKET:

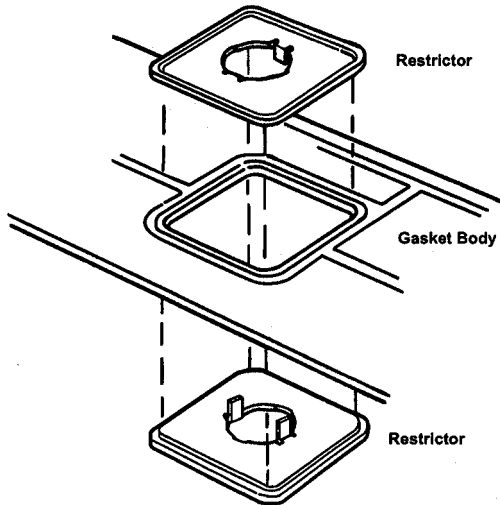

PLACE 1 RESTRICTOR HALF - with prongs up - on the work-bench.

POSITION THE CENTER PORT OF THE MANIFOLD GASKET over the restrictor half.

PLACE THE OTHER RESTRICTOR HALF OVER the gasket's center port.

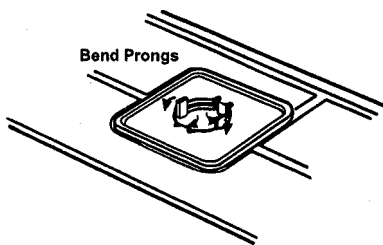

BEND THE 2 PRONGS OF THE LOWER RESTRICTOR HALF OUTWARD over the outer edge of the upper restrictor half using a blunt tool. Make certain the prongs are pressed down tightly so that the restrictor assembly is held securely in the gasket body. Turn the gasket over and repeat the prong bending operation with the other restrictor half.

IMPORTANT: When properly installed, the outer edge of the upper and lower restrictor halves will overlap the gasket body around the center port. Failure to do so may cause restrictor to slide out of position.

CLEAN MATING SURFACES of all foreign material including old gaskets, RTV, and oil. You may wish to use a degreaser.

CLEAR ALL THREADED HOLES in the cylinder head by using a bottoming tap.

CLEAN ALL BOLT THREADS by using a wire brush. Lubricate the threads and underside of every bolt head with oil.

CHECK MANIFOLD CASTINGS for flatness of gasket surface. Resurface or replace if severely distorted or corroded.

IMPORTANT The intake manifold end seals supplied in this set will only function with an intake manifold-to-cylinder block end gap measurement between .120" - .140".

DETERMINE END SEAL GAP

ATTACH AND ALIGN GASKET(S) TO CYLINDER HEAD(S) by fitting dowel pins of the gaskets into corresponding holes in the heads. **NOW ATTACH INTAKE MANIFOLD TO ENGINE.** Slightly tighten 4 corner bolts.

CHECK END GAP MEASUREMENT: Using a feeler gauge, measure the gap between the manifold and cylinder block at both ends.

REMOVE INTAKE MANIFOLD.

IF PRE-MEASURED END GAP is less than .120" or greater than .140" molded silicone rubber end seals **CANNOT** be installed. Instead create end seals by applying a continuous 1/4" bead of silicone sealer, across the front and rear ends of the cylinder block, from one cylinder head to the other.

IF PRE-MEASURED END GAP is between .120" - .140" install the molded silicone rubber end seals. These end seals must be installed **DRY** without any chemical adhesive.

PRIOR TO INSTALLING INTAKE MANIFOLD apply a small dab of silicone sealer, where all gaskets and seal(s) meet.

REINSTALL INTAKE MANIFOLD TO ENGINE. Torque securely to OEM specifications.

MISCELLANEOUS FLUID SEALING GASKETS

ATTACH AND ALIGN GASKET(S)/SEAL(S): If supplementary sealer is desired, apply a thin coat of gasket sealer to both sides of gasket(s). However, molded rubber gasket(s) or those with colored sealing beads, install **DRY**.



FEL-PRO INSTALLATION TIPS

INTAKE MANIFOLD GASKET

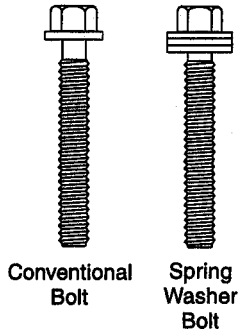

The gasket(s) included in this set will function with manifolds having either "Conventional" or "Spring Washer" style bolts.

Conventional bolts - Do Not torque beyond 22 ft. lbs.

Spring Washer bolts - Do Not torque beyond 12 ft. lbs.

RESTRICTED PORT GASKET:

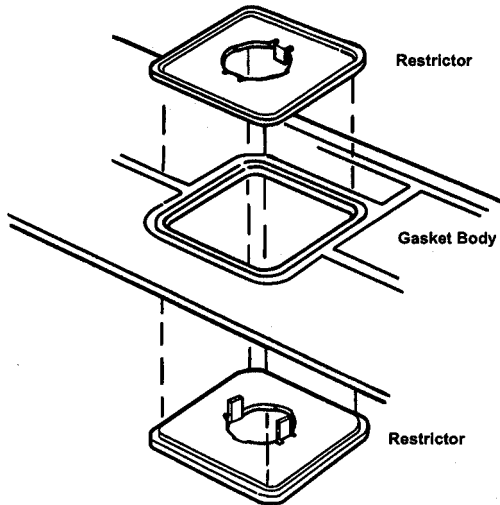

PLACE 1 RESTRICTOR HALF - with prongs up - on the work-bench.

POSITION THE CENTER PORT OF THE MANIFOLD GASKET over the restrictor half.

PLACE THE OTHER RESTRICTOR HALF OVER the gasket's center port.

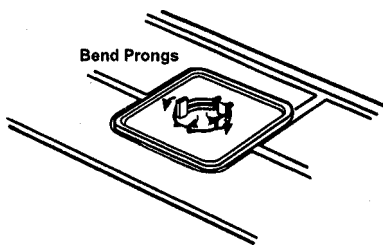

BEND THE 2 PRONGS OF THE LOWER RESTRICTOR HALF OUTWARD over the outer edge of the upper restrictor half using a blunt tool. Make certain the prongs are pressed down tightly so that the restrictor assembly is held securely in the gasket body. Turn the gasket over and repeat the prong bending operation with the other restrictor half.

IMPORTANT: When properly installed, the outer edge of the upper and lower restrictor halves will overlap the gasket body around the center port. Failure to do so may cause restrictor to slide out of position.

CLEAN MATING SURFACES of all foreign material including old gaskets, RTV, and oil. You may wish to use a degreaser.

CLEAR ALL THREADED HOLES in the cylinder head by using a bottoming tap.

CLEAN ALL BOLT THREADS by using a wire brush. Lubricate the threads and underside of every bolt head with oil.

CHECK MANIFOLD CASTINGS for flatness of gasket surface. Resurface or replace if severely distorted or corroded.

IMPORTANT The intake manifold end seals supplied in this set will only function with an intake manifold-to-cylinder block end gap measurement between .120" - .140".

DETERMINE END SEAL GAP

ATTACH AND ALIGN GASKET(S) TO CYLINDER HEAD(S) by fitting dowel pins of the gaskets into corresponding holes in the heads. **NOW ATTACH INTAKE MANIFOLD TO ENGINE.** Slightly tighten 4 corner bolts.

CHECK END GAP MEASUREMENT: Using a feeler gauge, measure the gap between the manifold and cylinder block at both ends.

REMOVE INTAKE MANIFOLD.

IF PRE-MEASURED END GAP is less than .120" or greater than .140" molded silicone rubber end seals **CANNOT** be installed. Instead create end seals by applying a continuous 1/4" bead of silicone sealer, across the front and rear ends of the cylinder block, from one cylinder head to the other.

IF PRE-MEASURED END GAP is between .120" - .140" install the molded silicone rubber end seals. These end seals must be installed **DRY** without any chemical adhesive.

PRIOR TO INSTALLING INTAKE MANIFOLD apply a small dab of silicone sealer, where all gaskets and seal(s) meet.

REINSTALL INTAKE MANIFOLD TO ENGINE. Torque securely to OEM specifications.

MISCELLANEOUS FLUID SEALING GASKETS

ATTACH AND ALIGN GASKET(S)/SEAL(S): If supplementary sealer is desired, apply a thin coat of gasket sealer to both sides of gasket(s). However, molded rubber gasket(s) or those with colored sealing beads, install **DRY**.