



FEL-PRO INSTALLATION TIPS

TIMING COVER SEALS

PRIOR TO INSTALLING THE SEAL apply a thin coat grease on the seal face.

IMPORTANT: Do not install any seal without break-in lubricant protection.

TIMING COVER

For 1986 and later applications having a one piece oil pan gasket, the oil pan must be removed and the gasket replaced. Disregard the oil pan end seal information.

CAREFULLY REMOVE TIMING COVER while holding oil pan front seal in place on oil pan.

CUT EXPOSED FRONT OIL PAN SEAL flush with the cylinder block using a sharp blade.

CLEAN MATING SURFACES of all foreign material including old gaskets, RTV and oil. You may wish to use a degreaser.

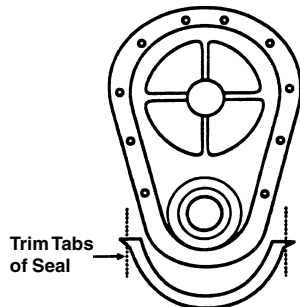

ATTACH AND ALIGN GASKET: Apply a quick-drying adhesive sparingly in several places on the engine casting or block. Attach gasket(s) on surface where adhesive was applied. **Allow time for adhesive to set.** Test for slippage with light pressure. If gasket moves, allow more time.

ATTACH AND ALIGN OIL PAN END SEAL.

PRIOR TO REINSTALLING COVER: Apply a 1/8" bead of RTV Black silicone sealer to the oil pan to block and seal to segment(s) intersections.

REINSTALL COVER TO ENGINE. Torque bolts evenly and slowly to OEM specifications. Now, apply a continuous bead of RTV Black silicone sealer, filling in the joint where the timing cover and oil pan meet.

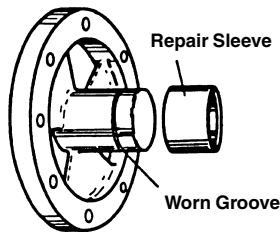
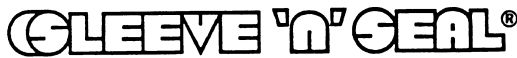

CLEAN BALANCER SURFACE of all foreign material.

INSTALL SLEEVE: Apply a thin coat of locking compound to the neck of the balancer. Using a flat block, tap sleeve gently over the shaft until it bottoms.

REMOVE ALL SEALER from outer surface of sleeve.

LURBICATE OUTER SURFACE of sleeve and lip by applying a thin coat of grease or motor oil.

TO COMPLETE INSTALLATION, use standard pulley installation procedures and standard seal.



FEL-PRO INSTALLATION TIPS

TIMING COVER SEALS

PRIOR TO INSTALLING THE SEAL apply a thin coat grease on the seal face.

IMPORTANT: Do not install any seal without break-in lubricant protection.

TIMING COVER

For 1986 and later applications having a one piece oil pan gasket, the oil pan must be removed and the gasket replaced. Disregard the oil pan end seal information.

CAREFULLY REMOVE TIMING COVER while holding oil pan front seal in place on oil pan.

CUT EXPOSED FRONT OIL PAN SEAL flush with the cylinder block using a sharp blade.

CLEAN MATING SURFACES of all foreign material including old gaskets, RTV and oil. You may wish to use a degreaser.

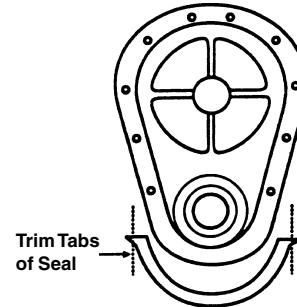

ATTACH AND ALIGN GASKET: Apply a quick-drying adhesive sparingly in several places on the engine casting or block. Attach gasket(s) on surface where adhesive was applied. **Allow time for adhesive to set.** Test for slippage with light pressure. If gasket moves, allow more time.

ATTACH AND ALIGN OIL PAN END SEAL.

PRIOR TO REINSTALLING COVER: Apply a 1/8" bead of RTV Black silicone sealer to the oil pan to block and seal to segment(s) intersections.

REINSTALL COVER TO ENGINE. Torque bolts evenly and slowly to OEM specifications. Now, apply a continuous bead of RTV Black silicone sealer, filling in the joint where the timing cover and oil pan meet.

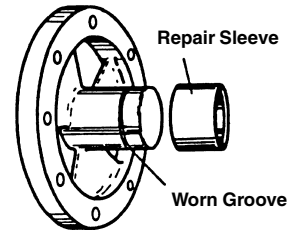
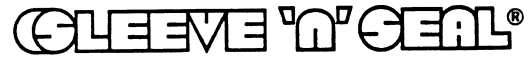

CLEAN BALANCER SURFACE of all foreign material.

INSTALL SLEEVE: Apply a thin coat of locking compound to the neck of the balancer. Using a flat block, tap sleeve gently over the shaft until it bottoms.

REMOVE ALL SEALER from outer surface of sleeve.

LURBICATE OUTER SURFACE of sleeve and lip by applying a thin coat of grease or motor oil.

TO COMPLETE INSTALLATION, use standard pulley installation procedures and standard seal.