



GM Multi Kit 1994-2012

Visit MetraOnline.com for more detailed information about the product and up-to-date vehicle specific applications

KIT FEATURES

- 95-2001
 - ISO DDIN radio provision
- 99-2001
 - ISO DIN radio provision with pocket

KIT COMPONENTS

- 95-2001: • A1) Radio trim plate • B1) Radio brackets • C1) Spacers
99-2001: • A2) Radio trim plate • B2) Radio brackets • C2) Spacers • D2) Pocket • E2) (4) #8 x 3/8" Phillips screws

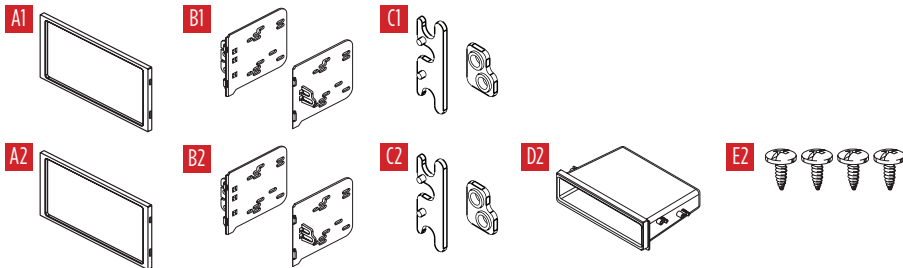

APPLICATIONS

See page 2

TABLE OF CONTENTS

See page 3

WIRING & ANTENNA CONNECTIONS (sold separately)

Wiring Harness: Visit metraonline.com for audio/video and steering wheel control interface options.
Antenna Adapter: 40-GM10 • 40-CR10

TOOLS REQUIRED

- Phillips screwdriver • Socket set
- Utility knife (95-2001)

Attention! With the key out of the ignition, disconnect the negative battery terminal before installing this product. Ensure that all installation connections are secure before cycling the ignition to test this product.

APPLICATIONS (95-2001 OR 99-2001)

BUICK

Century	1997-2005
Le Sabre	1995-2005
Park Avenue	1995-2005
Rainier	2004-2007
Regal.....	1995-2004
Rendezvous.....	2002-2007
Riviera.....	1996-1999
Roadmaster.....	1995-1996
Skylark.....	1996-1998

CADILLAC

Escalade, Escalade ESV & EXT	2003-2006
---------------------------------------	-----------

CHEVROLET

Avalanche.....	2003-2006
Blazer.....	2002-2005
Cavalier.....	2000-2005
Colorado.....	2004-2012
Express Van (full size).....	2001-2007

CHEVROLET (CONT)

Impala.....	2000-2005
Kodiak.....	2003-2009
Malibu.....	2001-2003
Malibu Classic.....	2004-2005
Monte Carlo.....	2000-2005
S-10 (with ISO DDIN radio).....	2002-2004

Silverado.....	2003-2006
Silverado Classic.....	2007
Suburban.....	2003-2006
Tahoe.....	2003-2006
Trailblazer.....	2002-2009
Venture.....	2000-2005

GMC

Canyon.....	2004-2012
Envoy.....	2002-2009
Savanna.....	2001-2007

GMC (CONT)

Sierra.....	2003-2006
Sierra Classic	2007
Sonoma (with ISO DDIN radio).....	2002-2004
TopKick.....	2005-2009
Yukon.....	2003-2006

HUMMER

H2.....	2003-2007
---------	-----------

ISUZU

Ascender.....	2003-2008
H-Series.....	2003-2008
I-290/I370.....	2007-2008
I-280/I350.....	2006

OLDSMOBILE

Achieva.....	1996-1998
Alero.....	1999-2004

OLDSMOBILE (CONT)

Aurora.....	1995-2003
Bravada.....	1998-2004
Cutlass.....	1997-1999
Cutlass Supreme.....	1995-1997
Eighty-Eight.....	1994-1999
Intrigue.....	1998-2002
LSS.....	1996-1999
Ninety-Eight.....	1994-1996
Regency.....	1997-1998
Silhouette.....	2000-2004

PONTIAC

Aztec.....	2001-2005
Bonneville.....	2000-2005
Grand Am.....	2001-2005
Montana.....	2000-2005
Sunfire.....	2000-2005

TABLE OF CONTENTS

Dash Disassembly

- Buick Century 1997-2005	4	- Chevrolet Monte Carlo 2000-2005.....	10	- Oldsmobile Achieva 1996-1998.....	15
- Buick Le Sabre 1995-2005.....	4	- Chevrolet S-10 (with ISO DDIN radio) 2002-2004	7	- Oldsmobile Alero 1999-2004.....	15
- Buick Park Avenue 1995-2005.....	4	- Chevrolet Silverado/Classic 2003-2007	7	- Oldsmobile Aurora 1995-2003.....	15
- Buick Rainier 2004-2007	13	- Chevrolet Suburban 2003-2006.....	7	- Oldsmobile Bravada 1998-2001.....	7
- Buick Regal 1995-2004.....	4	- Chevrolet Tahoe 2003-2006	7	- Oldsmobile Bravada 2002-2004	13
- Buick Rendezvous 2002-2007	5	- Chevrolet Trailblazer 2002-2009	11	- Oldsmobile Cutlass 1997-1999	16
- Buick Riviera 1996-1999	5	- Chevrolet Venture 2000.....	11	- Oldsmobile Cutlass Supreme 1995-1997	13
- Buick Roadmaster 1995-1996	6	- Chevrolet Venture 2001-2005.....	12	- Oldsmobile Eighty-Eight 1994-1999.....	16
- Buick Skylark 1996-1998.....	6	- GMC Canyon 2004-2008.....	8	- Oldsmobile Intrigue 1998-2002.....	16
- Cadillac Escalade, Escalade ESV & EXT 2003-2006.....	7	- GMC Envoy 2002-2007.....	13	- Oldsmobile LSS 1996-1999	17
- Chevrolet Avalanche 2003-2006.....	7	- GMC Savanna 2001-2002.....	8	- Oldsmobile Ninety-Eight 1994-1996	16
- Chevrolet Blazer 2002-2005	7	- GMC Savanna 2003-2007.....	9	- Oldsmobile Regency 1997-1998	17
- Chevrolet Cavalier 2000-2005.....	8	- GMC Sierra/Classic 2003-2007	7	- Oldsmobile Silhouette 2000.....	11
- Chevrolet Colorado 2004-2008	8	- GMC Sonoma (with ISO DDIN radio) 2002-2004	7	- Oldsmobile Silhouette 2001-2004	12
- Chevrolet Express Van (full size) 2001-2002	9	- GMC TopKick 2005-2009	7	- Pontiac Aztec 2001-2005	17
- Chevrolet Express Van (full size) 2003-2007.....	9	- GMC Yukon/Denali/XL 2003-2006.....	7	- Pontiac Bonneville 2000-2005.....	17
- Chevrolet Impala 2000-2005	10	- Hummer H2 2003-2007	14	- Pontiac Grand Am 2001-2005	18
- Chevrolet Kodiak 2003-2009.....	7	- Isuzu Ascender 2003-2005.....	13	- Pontiac Montana 2000 (Except SV6)	11
- Chevrolet Malibu 2001-2003.....	10	- Isuzu H-Series 2003-2008	7	- Pontiac Montana 2001-2005 (Except SV6)	12
- Chevrolet Malibu Classic 2004-2005.....	10	- Isuzu I-290/I370 2007-2008.....	8	- Pontiac Sunfire 2000-2005	18
		- Isuzu I-280/I350 2006.....	8	Kit Assembly.....	19

DASH DISASSEMBLY 95-2001 OR 99-2001

Buick Century 1997-2005

Buick Regal 1995-2004

1. Remove the plastic trim piece to the left of the glove box and (1) Phillips screw exposed.
2. Unsnap the top edge of the knee bolster panel.
3. Remove (1) Phillips screw from the panel.
4. Remove the ashtray cluster and (2) Phillips screws from each side.
5. Unclip the entire dash trim bezel and remove.
6. Open doors and unsnap end caps from each side of dash.
7. Unsnap and remove radio/instrument cluster panel.
8. Remove (3) screws in order to remove radio.

Continue to Kit Assembly

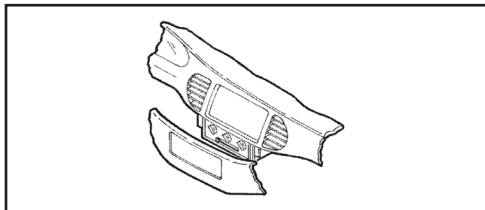

(Figure A)

Buick Le Sabre/Buick Park Avenue 1995-1999

1. Unsnap the climate control trim panel (from door to door) and remove (4) Phillips screws exposed. (Figure A)
2. Pop out the a/c vents and remove (1) Phillips screw exposed in each vent cavity. (Figure A)
3. Unclip the radio trim bezel and remove.
4. Remove the screws securing the factory radio and disconnect the wiring.

Continue to Kit Assembly

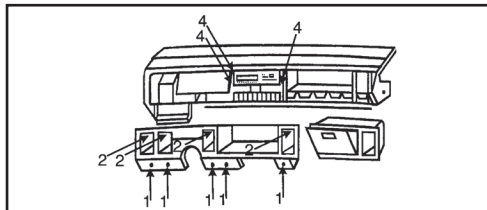

(Figure A)

Buick Le Sabre/Buick Park Avenue 2000-2005

1. Open drivers door and unsnap and remove dash end cap.
2. Unsnap and remove trim along center of dash (one piece on right and one on left of wheel).
3. Unsnap and remove radio/instrument bezel.
4. Remove (2) screws in order to remove radio.

Note: For the Buick LeSabre, (3) speed clips and screws will need to be supplied to attach the kit into the subdash where the screw holes line up with the kit.

Continue to Kit Assembly

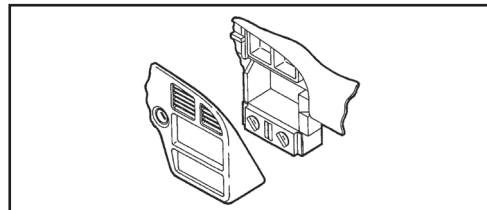

(Figure A)

DASH DISASSEMBLY 95-2001 OR 99-2001

Buick Rendezvous 2002-2007

1. Open center console and remove (2) screws at front of console opening. (Figure A)
2. Remove liners from cup holders and storage pocket next to cup holders, then remove screws. Unsnap and remove panel. (Figure B)
3. Remove (2) screws from bottom of radio/climate control bezel, unclip and remove. (Figure C)
4. Remove (3) 9/32" hex-head screws to remove radio. (Figure D)

Continue to Kit Assembly

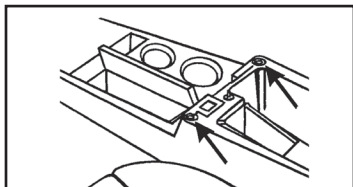

(Figure A)

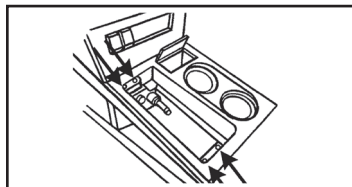

(Figure B)

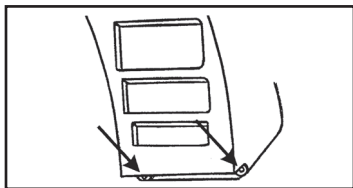

(Figure C)

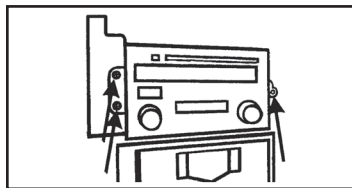

(Figure D)

Buick Riviera 1996-1999

1. Unsnap left side panel exposing (1) Phillips screw to remove.
2. Remove (1) Phillips screw and unsnap right side panel to expose (1) Phillips screw beneath panel and remove.
3. Unsnap underside of overhanging dash to unsnap (6) plastic rivets and remove panel.
4. Remove (5) hex-head screws now exposed under overhang.
5. Unsnap bottom edge of trim bezel, then while holding overhang up, unsnap and remove trim bezel by removing any necessary harnesses.
6. Remove (3) Phillips screw to remove climate control.
7. Remove (2) Phillips screws to remove rear support and (3) 9/32"

Continue to Kit Assembly

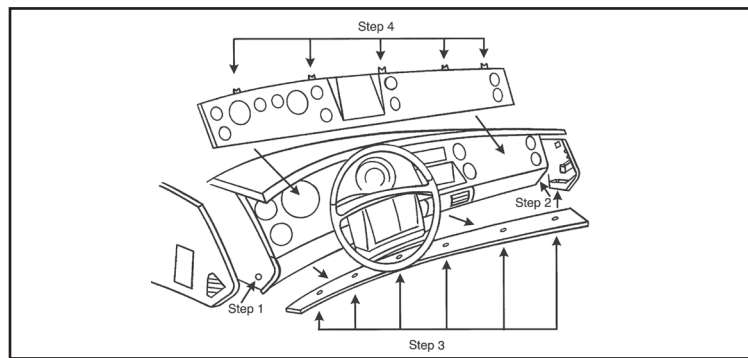

(Figure A)

DASH DISASSEMBLY 95-2001 OR 99-2001

Buick Roadmaster 1995-1996

1. Unclip dash panel sides and remove.
2. Unclip panel below steering column and remove.
3. Remove (2) 7mm screws above instrument cluster.
4. Set parking brake, turn car on, and move shifter to the lowest gear. Tilt steering wheel down then unsnap entire instrument cluster/radio panel and remove.
5. Remove (3) 7mm screws to remove radio.

Continue to Kit Assembly

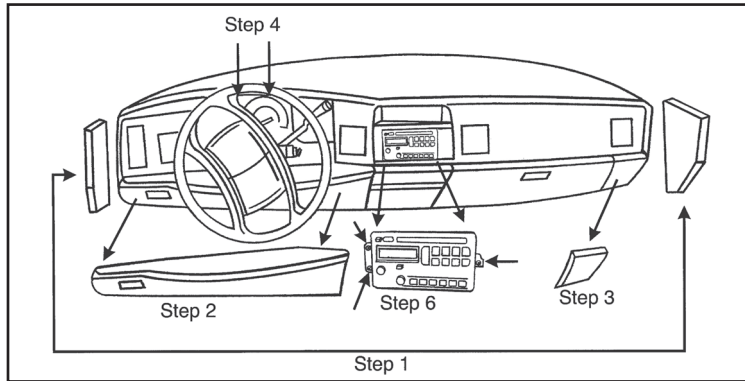

(Figure A)

Buick Skylark 1996-1998

1. Remove (6) 9/32" screws inside glove box.
2. Under glove box and drivers knee bolster, remove (2) plastic panels by turning (2) 1/4 turn fasteners per side.
3. Remove (4) 9/32" screws revealed (2 per side).
4. Unsnap panel from driver's side to passenger's side.
5. Remove (3) 9/32" screws.

Continue to Kit Assembly

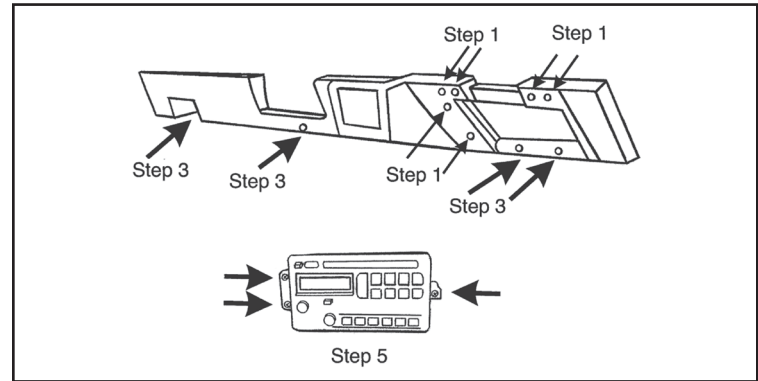

(Figure A)

DASH DISASSEMBLY 95-2001 OR 99-2001

**Cadillac Escalade, Escalade ESV & EXT 2003-2006,
Chevrolet Avalanche/Suburban/Tahoe 2003-2006,
Chevrolet Kodiak 2003-2009,
Chevrolet Silverado/Classic 2003-2007,
GMC Sierra/Classic 2003-2007, GMC TopKick 2003-2009,
GMC Yukon/Denali/XL 2003-2006, Isuzu H-Series 2003-2008**

1. Unsnap and remove dash bezel.
2. Remove (3) 9/32" screws and remove radio.

Continue to Kit Assembly

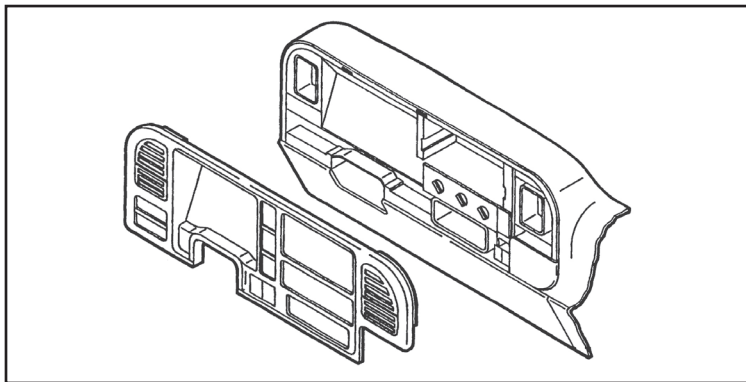

(Figure A)

**Chevrolet Blazer 2002-2005,
S-10/GMC Sonoma (with ISO DDIN radio) 2002-2004,
Oldsmobile Bravada 1998-2001**

1. Remove (2) 9/32" hex-head screws from the knee bolster panel.
2. Pull down on the panel and remove the 9/32" hex-head screws exposed on the bottom of the dash trim bezel.
3. Remove (1) Phillips screw above the instrument cluster.
4. Unclip the dash trim bezel and remove.
5. Remove (2) 9/32" hex-head screws securing the factory head unit and disconnect the wiring.

Continue to Kit Assembly

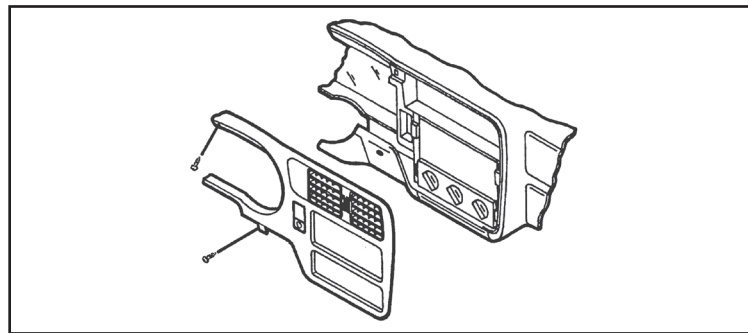

(Figure A)

DASH DISASSEMBLY 95-2001 OR 99-2001

Chevrolet Cavalier 2000-2005

1. Open drivers door and remove fuse panel on end of dash.
2. Open passenger door and remove panel on end of dash.
3. Remove (1) Phillips screw from each side exposed.
4. Remove (3) screws from top of glove box liner.
5. Remove (2) screws from the top-left corner of the glove box cavity.
6. Remove (1) Phillips screw from the defroster duct.
7. Remove the ductwork and (1) Phillips screw exposed.
8. Remove the dash pad and (3) Phillips screws exposed at the top of the radio trim bezel.

Continue to Kit Assembly

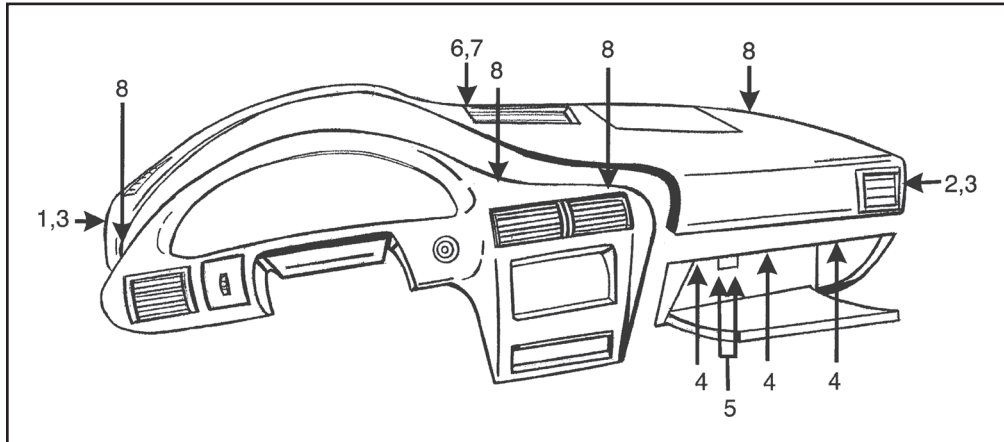

(Figure A)

Chevrolet Colorado 2004-2008, GMC Canyon 2004-2008, Isuzu I-290/I-370 2007-2008, Isuzu I-280/I-350 2006

1. Unsnap and remove the entire panel surrounding the radio and A/C controls. (Figure A)
2. Remove (3) 9/32" screws securing the radio to remove. (Figure B)

Continue to Kit Assembly

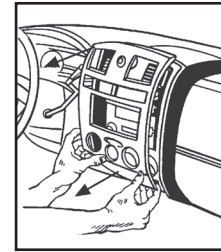

(Figure A)

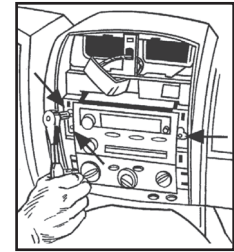

(Figure B)

DASH DISASSEMBLY 95-2001 OR 99-2001

Chevrolet Express Van 2001-2002, GMC Savanna 2001-2002

1. Unsnap and remove small trim panel below steering column. (Figure A)
2. Unsnap radio/climate/instrument panel. (Figure B)
3. Move shift lever to first gear position.
4. Rotate panel counterclockwise to lift over steering column and remove.
5. Remove (3) 9/32" hex-head screws to remove radio.

Continue to Kit Assembly

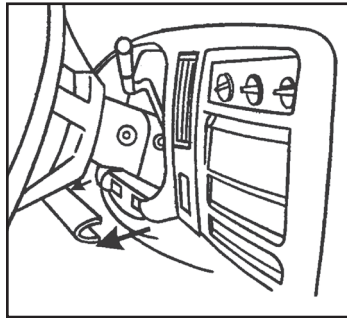

(Figure A)

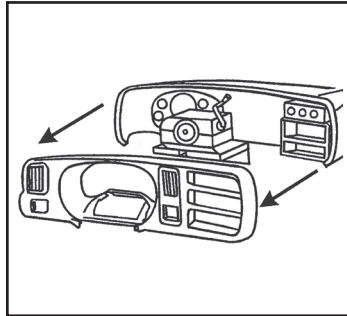

(Figure B)

Chevrolet Express Van 2003-2007, GMC Savanna 2003-2007

1. Remove (2) 10mm bolts from below knee bolster under steering column and remove panel. (Figure A)
2. Remove (2) 10mm bolts from panel below passenger dash airbag and remove panel. (Figure B)
3. Remove (2) 10mm nuts from inside center pocket between power outlets. (Figure C)
4. Unsnap and remove radio and instrument cluster panel. (May not be necessary to completely remove radio and instrument cluster panel to access radio.)
5. Remove (3) 9/32" bolts to remove radio.

Continue to Kit Assembly

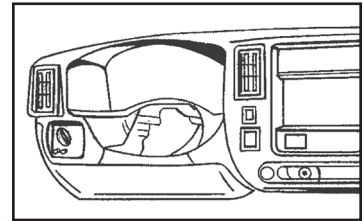

(Figure A)

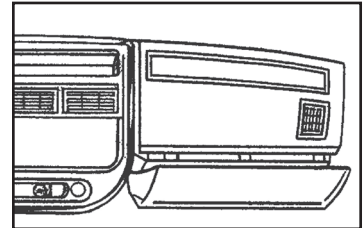

(Figure B)

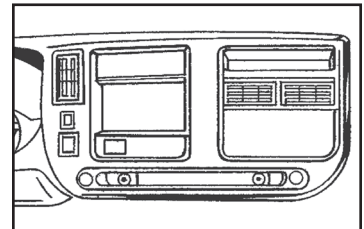

(Figure C)

DASH DISASSEMBLY 95-2001 OR 99-2001

Chevrolet Impala 2000-2005

1. Unclip each side of the dash trim bezel (fuse access) and remove (1) Phillips screw exposed on each side.
2. Remove (2) Phillips screws under the instrument cluster.
3. Unclip the trim panel above the pedals. (It is not necessary to remove the panel it can be left hanging).
4. Remove (2) Phillips screws from the knee panel.
5. Unclip the knee panel and remove (1) Phillips screw exposed on the right side of the steering column.
6. Unclip and remove the entire dash trim bezel.

Continue to Kit Assembly

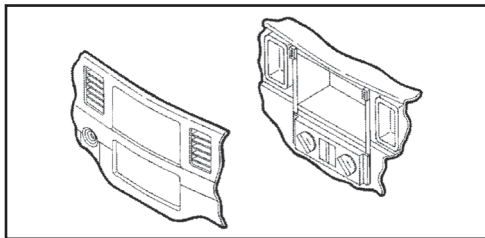

(Figure A)

Chevrolet Malibu 2001-2003, Chevrolet Malibu Classic 2004-2005

1. Unsnap and remove radio bezel.
2. Remove (3) bolts and remove radio.

Continue to Kit Assembly

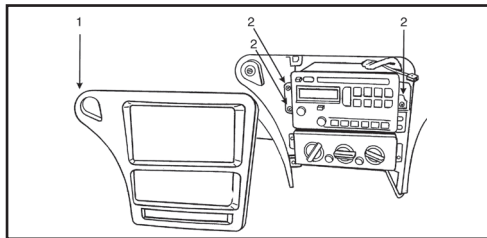

(Figure A)

Chevrolet Monte Carlo 2000-2005

1. Unclip the trim panel above the pedals. (It is NOT necessary to remove the panel it may be left hanging.)
2. Remove (2) 9/32" screws from the knee panel and unclip the panel.
3. Unsnap the driver's side fuse panel cover and remove (1) 9/32" screw.
4. Open the glove box and remove (1) 9/32" screw from the upper left corner.
5. Remove (3) 9/32" screws securing the factory radio and disconnect the wiring.

Continue to Kit Assembly

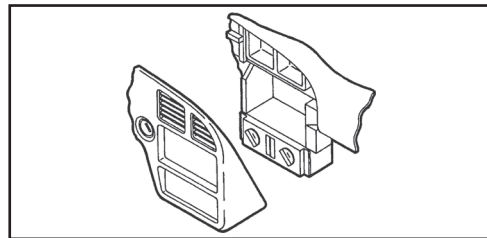

(Figure A)

DASH DISASSEMBLY 95-2001 OR 99-2001

Chevrolet Trailblazer 2002-2009

1. Remove (2) Phillips screws inside instrument cluster.
2. Remove (1) Phillips screw under climate controls to the left of the power outlet.
3. Remove (2) 7mm hex-heads from under steering column and lower the panel. Remove (3) Phillips screws around steering wheel.
4. Unsnap and remove bezel. (Use caution pulling over hazard switch.) Remove (3) 7mm hexhead screws to remove radio.

Continue to Kit Assembly

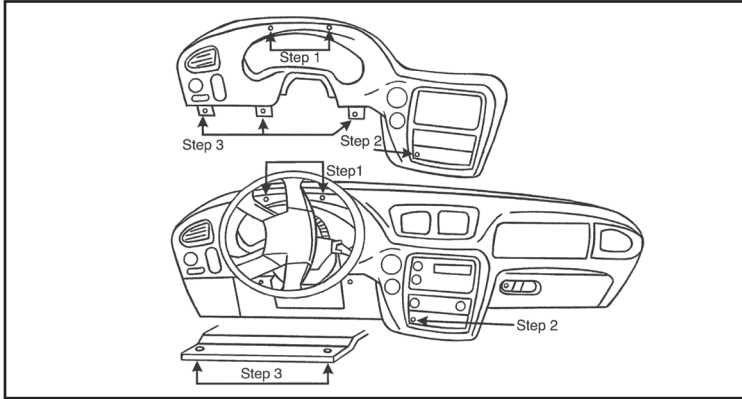

(Figure A)

Chevrolet Venture 2000, Oldsmobile Silhouette 2000, Pontiac Montana 2000 (Except SV6)

1. Remove the ashtray and (1) Phillips screw exposed in the ashtray cavity.
2. Remove (1) Phillips screw from the cigarette lighter compartment.
3. Remove (2) Phillips screws securing the factory radio and disconnect the wiring.

Continue to Kit Assembly

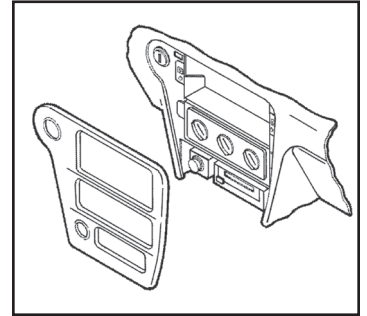

(Figure A)

DASH DISASSEMBLY 95-2001 OR 99-2001

**Chevrolet Venture 2001-2005,
Oldsmobile Silhouette,
2001-2004 Pontiac Montana 2001-2005**
(Except SV6)

1. Open cup holders and remove (2) Phillips 7mm screws. (Figure A)
2. Unsnap and remove dual power outlet assembly from lower storage.
3. Open lower storage door and remove (2) 7mm screws inside.
4. Models with DVD - Remove DVD player and remove (2) 7mm screws from behind and (2) 7mm screws near the floor.
5. Remove lower storage compartment. (Figure B)

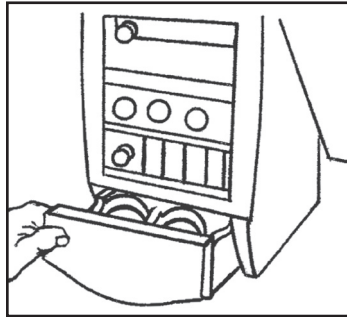

(Figure A)

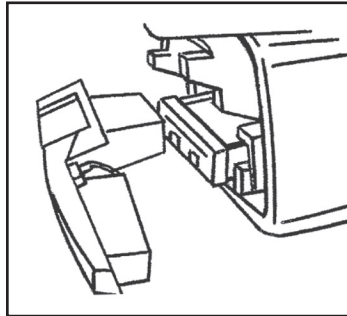

(Figure B)

6. Remove (2) 7mm screws (facing up) from under cup holder. (Figure C)
7. Remove (3) 7mm hex-head screws and remove radio. (Figure D)

Continue to Kit Assembly

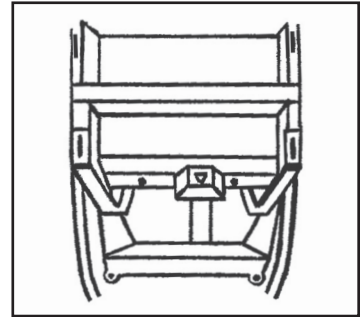

(Figure C)

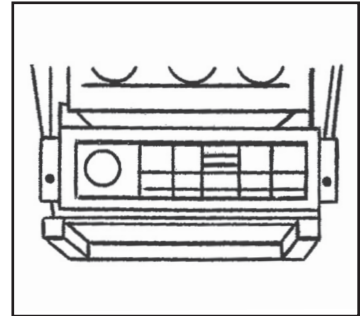

(Figure D)

DASH DISASSEMBLY 95-2001 OR 99-2001

**GMC Envoy 2002-2007,
Isuzu Ascender 2003-2005,
Oldsmobile Bravada 2002-2004,
Buick Ranier 2004-2007**

1. Remove (4) Phillips screws, (2) from left and (2) from right of carpeted panel. (Figure A)
2. Slide carpeted panel down and backwards to reveal (2) Phillips screws and remove. (Figure B)
3. Unsnap radio bezel and unplug cigarette lighter and accessories. (Figure C)
4. Remove (3) screws and remove radio. (Figure C)

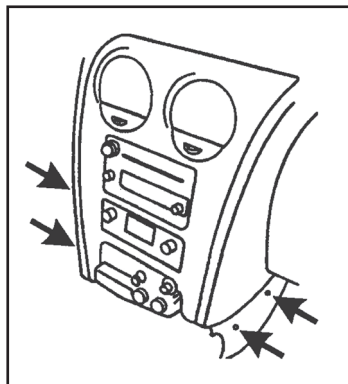

(Figure A)

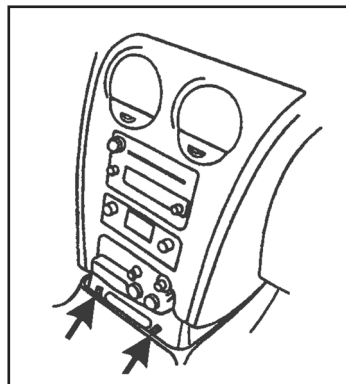

(Figure B)

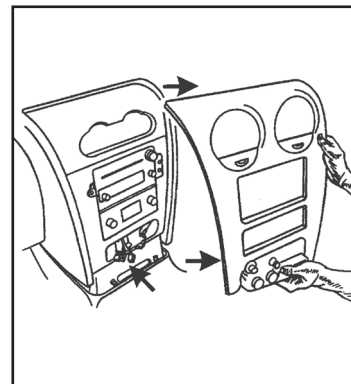

(Figure C)

Continue to Kit Assembly

DASH DISASSEMBLY 95-2001 OR 99-2001

Hummer H2 2003-2007

1. Open center console and remove (4) 9/32" screws from console box and remove box. (Figure A)
2. Remove (4) Phillips screws from hinge on console door inside console and remove door. (Figure B)
3. Loosen (1) T-15 torx on forward facing side of shift lever and pull up to remove. (Figure C)
4. Unclip cup holder/shifter trim assembly and remove. (Figure D)
5. Remove (6) Phillips screws from top of center console. (Figure F)

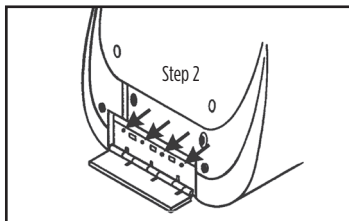

(Figure B)

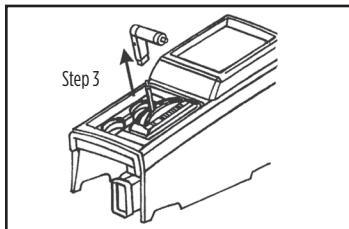

(Figure C)

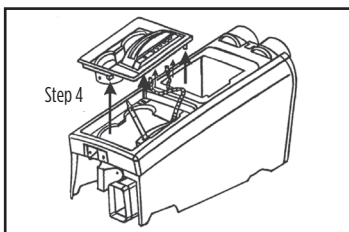

(Figure D)

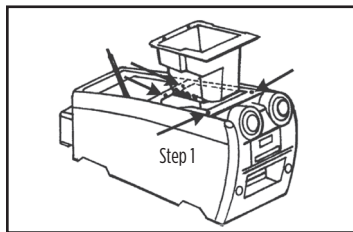

(Figure A)

6. Remove (2) Phillips screws from inside pocket on back of center console, then unclip and remove. (Figure E)
7. Remove (1) 10mm bolt to right of shift lever. (Figure E)
8. Remove (2) Phillips screws from under console box on drivers side and (2) Phillips screws from under console trimtop on passenger side. (Figure F)
9. Slide control assembly rearwards. (Figure G)
10. Remove (2) T-30 torx bolts from top of rado/climate control trim and unclip and remove. (Figure G)
11. Remove (3) 9/32" screws that hold the radio in. (Figure G)

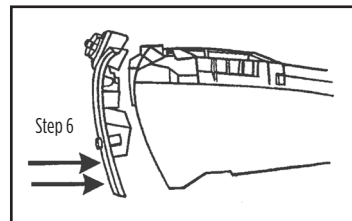

(Figure E)

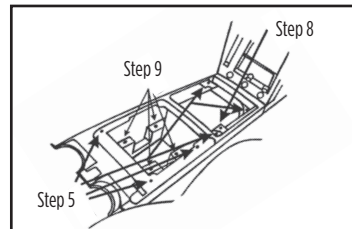

(Figure G)

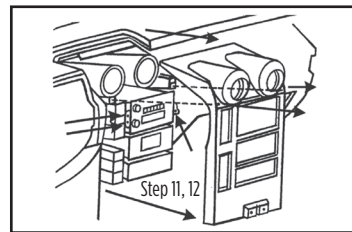

(Figure G)

Continue to Kit Assembly

DASH DISASSEMBLY 95-2001 OR 99-2001

Oldsmobile Achieva 1996-1998

1. Open the glove box, press inward on the walls of the glove box liner and remove the liner.
2. Remove (10) torx-head screws from the glove box location.
3. Remove (2) 9/32" hex-head screws under the steering column.
4. Unclip the dash trim bezel. (Figure A)
5. Remove the screws securing the factory radio and disconnect the wiring.

Continue to Kit Assembly

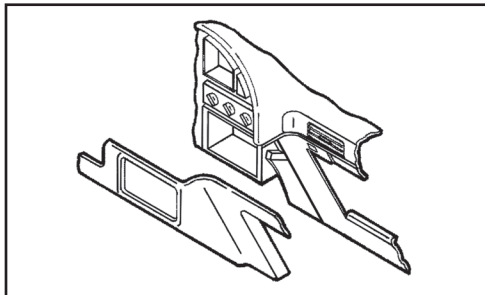

(Figure A)

Oldsmobile Alero 1999-2004

1. Remove shift knob by using a small screwdriver to remove U-clip from front of shifter and pull upward.
2. Unclip and remove shifter trim panel.
3. Unclip and remove radio and climate control panel by pulling from bottom. (Figure A)
4. Remove (3) 9/32" screws from radio and remove.

Continue to Kit Assembly

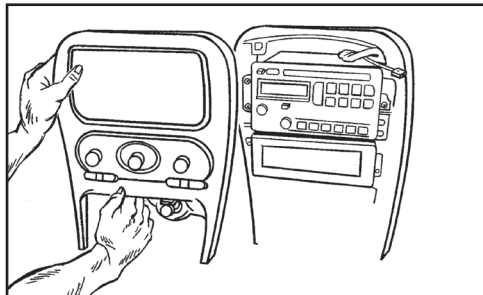

(Figure A)

Oldsmobile Aurora 1995-2003

1. Unclip the radio trim bezel and remove the bezel. (Figure A)
2. Remove (2) 7mm screws securing the factory radio and disconnect the wiring.

Note: For the 2001-2003 models, (3) speed clips and screws will need to be supplied to attach the kit into the sub-dash where the screw holes line up with the kit.

Continue to Kit Assembly

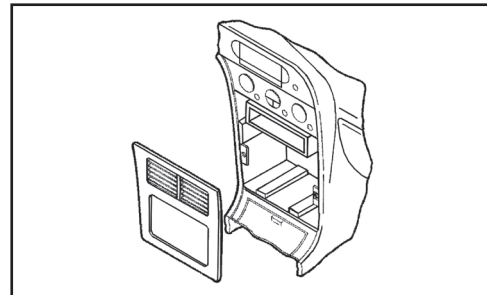

(Figure A)

DASH DISASSEMBLY 95-2001 OR 99-2001

Oldsmobile Cutlass 1997-1999, Oldsmobile Cutlass Supreme 1995-1997

1. Unclip the radio trim bezel and remove. (Figure A)
2. Remove (2) $9/32$ " hex-head screws securing the factory radio and disconnect the wiring.

Continue to Kit Assembly

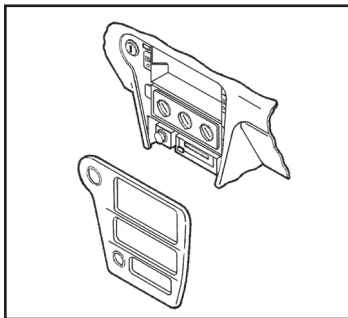

(Figure A)

Oldsmobile Eighty-Eight 1994-1999

1. Unclip the radio trim bezel and remove.
2. Remove (2) $9/32$ " hex-head screws securing the factory radio and disconnect the wiring.

Continue to Kit Assembly

Oldsmobile Ninety-Eight 1994-1996

1. Open the glove box and remove (2) hex-head screws securing the wood trim.
2. Unsnap the wood trim and remove.
3. Remove (2) hex-head screws below the radio trim bezel.
4. Lift up on the bezel and remove.
5. Remove (3) Phillips hex-head screws securing the factory radio and disconnect the wiring.

Continue to Kit Assembly

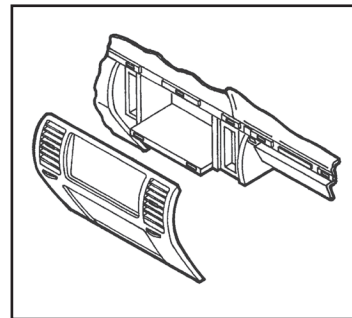

(Figure A)

Oldsmobile Intrigue 1998-2002

1. Open the center console storage compartment and remove (2) $9/32$ " hex-head screws exposed.
2. Remove the center console.
3. Unclip the radio trim bezel and remove.
4. Remove (2) $9/32$ " hex-head screws securing the factory radio and disconnect the wiring.

Continue to Kit Assembly

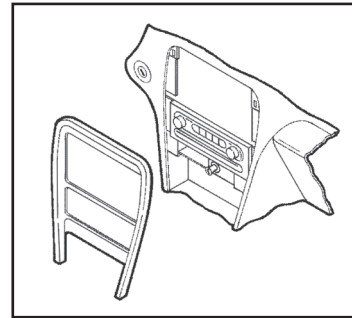

(Figure A)

DASH DISASSEMBLY 95-2001 OR 99-2001

Oldsmobile LSS 1996-1999 / Regency 1997-1998

1. Open glove box and remove two-center trim bezels attached by screws. (Figure A)
2. Unsnap and remove radio trim bezel. (Figure A)
3. Remove (3) 9/32" hex-head screws and remove radio. (Figure B)

Continue to Kit Assembly

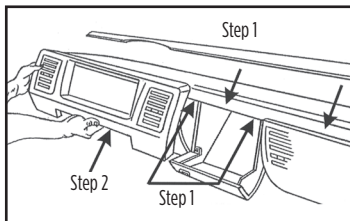

(Figure A)

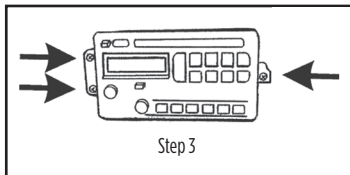

(Figure B)

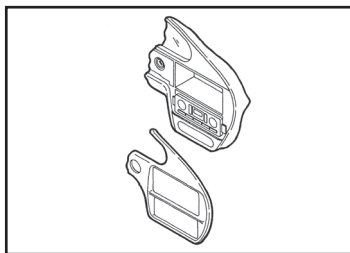

(Figure A)

Pontiac Aztec 2001-2005

1. Pull out cup holder inserts.
2. Remove (1) Phillips screw exposed inside bottom cup holder.
3. Unsnap and remove shifter trim with cup holders.
4. Remove (2) #15 torx at bottom of radio/ climate bezel.

Continue to Kit Assembly

Pontiac Bonneville 2000-2005

1. Remove (2) Phillips screws from the instrument cluster. (Figure A)
2. Unclip the ignition trim and remove. (Figure B)
3. Unclip the climate control/radio trim bezel and remove.
4. Depress the spring clips on each side of the factory head unit and remove. (Figure C)

Note: (3) speed clips and screws will need to be supplied to attach the kit into the sub-dash where the screw holes line up with the kit.

Continue to Kit Assembly

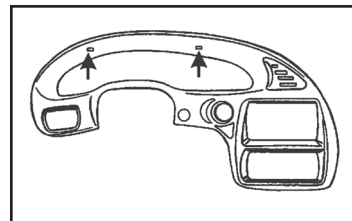

(Figure A)

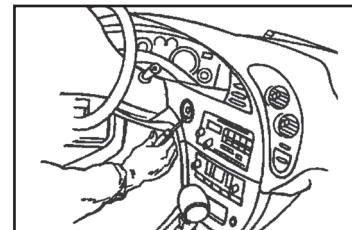

(Figure B)

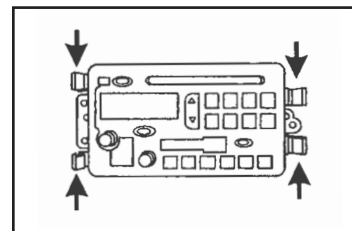

(Figure C)

DASH DISASSEMBLY 95-2001 OR 99-2001

Pontiac Grand Am 2001-2005

1. Unsnap and remove radio trim bezel. (Figure A)
2. Remove (3) 9/32" screws from radio brackets and remove radio. (Figure B)

Continue to Kit Assembly

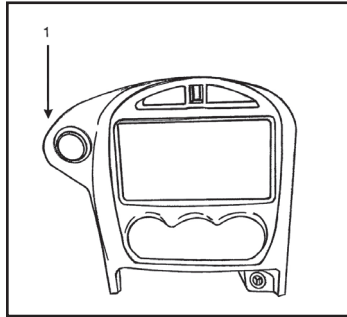

(Figure A)

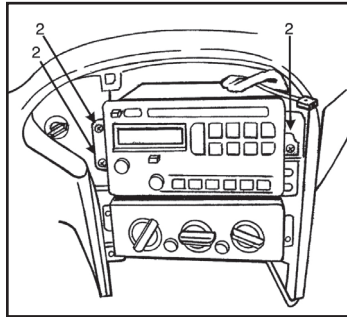

(Figure B)

Pontiac Sunfire 2000-2005

1. Open the glove box and remove (2) Phillips screws exposed on the right edge of the radio trim bezel.
2. Unclip the bezel and remove.
3. Remove (2) 7mm hex-head screws securing the factory head unit and disconnect the wiring.

Continue to Kit Assembly

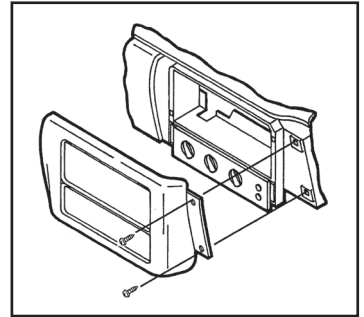

(Figure A)

KIT ASSEMBLY

ISO DDIN radio provision (95-2001):

1. Attach the **radio brackets** to the inside edge of the **radio trim plate**. (Figure A)
2. Slide the radio into the completed assembly, then secure using screws supplied with the radio. (Figure B)
3. Locate the factory wiring harness and antenna connector in the dash and complete all necessary connections to the radio. Metra recommends using the proper mating adapter from Metra and/or Axxess. Test the radio for proper operation.
4. Reassemble the dash in reverse order of disassembly to complete the installation.

Note: The spacers included in the kit may be necessary to adapt to the slight differences from one vehicle to another. If the kit/radio assembly does not meet the backside of the factory radio opening, use the spacers to eliminate that space.

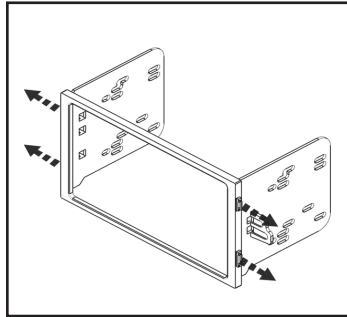

(Figure A)

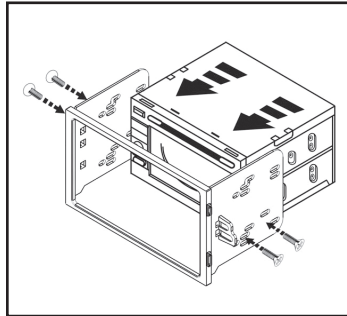

(Figure B)

ISO DIN radio provision with pocket (99-2001):

1. Attach the **radio brackets** to the inside edge of the **radio trim plate**. (Figure A)
 2. Slide the **pocket** into the assembly, and then secure using the (4) #8 x 3/8" Phillips screws provided. (Figure B)
 3. Remove the metal DIN sleeve and trim ring from the aftermarket radio.
 4. Slide the radio into the bracket/pocket assembly, then secure using screws supplied with the radio. (Figure B)
 5. Locate the factory wiring harness and antenna connector in the dash and complete all necessary connections to the radio. Metra recommends using the proper mating adapter from Metra and/or Axxess. Test the radio for proper operation.
 6. Reassemble the dash in reverse order of disassembly to complete the installation.
- Note:** The spacers included in the kit may be necessary to adapt to the slight differences from one vehicle to another. If the kit/radio assembly does not meet the backside of the factory radio opening, use the spacers to eliminate that space.

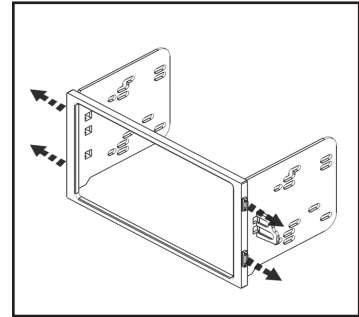

(Figure A)

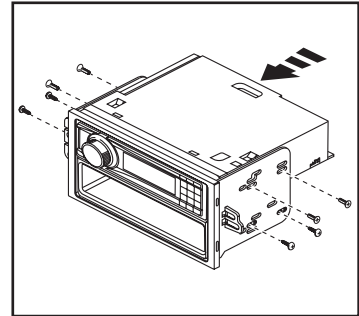

(Figure B)



INST-2001

INSTALLATION INSTRUCTIONS



Having difficulties? We're here to help.



Contact our Tech Support line at:

386-257-1187



Or via email at:

techsupport@metra-autosound.com

Tech Support Hours (Eastern Standard Time)

Monday - Friday: 9:00 AM - 7:00 PM

Saturday: 10:00 AM - 7:00 PM

Sunday: 10:00 AM - 4:00 PM



KNOWLEDGE IS POWER

Enhance your installation and fabrication skills by enrolling in the most recognized and respected mobile electronics school in our industry. Log onto www.installerinstitute.edu or call 386-672-5771 for more information and take steps toward a better tomorrow.



Metra recommends MECP certified technicians



GM Multi Kit 1994-2012

Visite MetraOnline.com para obtener información más detallada sobre el producto y aplicaciones actualizadas específicas para vehículos.

CARACTERÍSTICAS DEL KIT

95-2001

- Provisión de radio ISO DDIN

99-2001

- Provisión de radio ISO DIN con cavidad

COMPONENTES DEL KIT

95-2001: • A1) Placa de moldura de radio • B1) Soportes del radio • C1) Espaciadores

99-2001: • A2) Placa de moldura de radio • B2) Soportes del radio • C2) Espaciadores • D2) Cavidad • E2) (4) Tornillos Phillips #8 de 3/8"

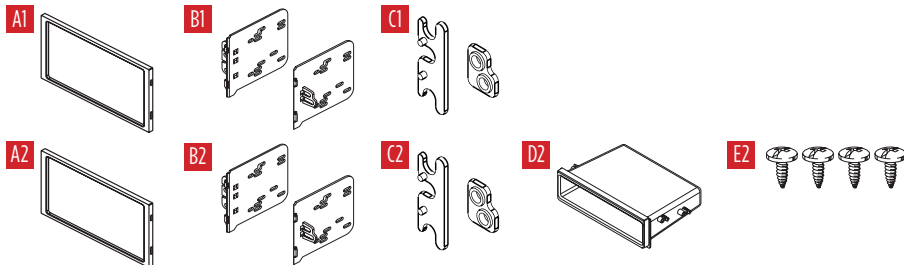

APPLICATIONS

Vea la página 2

INDICE

Vea la página 3

CABLEADO Y CONEXIONES DE ANTENA

(se venden por separado)

Árnés de cableado: Visite metraonline.com para conocer las opciones de interfaz de control del volante y audio / video.

Adaptador de antena: 40-GM10 • 40-CR-10

HERRAMIENTAS NECESARIAS

- Phillips screwdriver • Llave de tubo
- Cuchillo de uso (95-2001)

¡Atención! Deje que el vehículo se asiente con la llave fuera del encendido durante unos minutos antes de quitar la radio de fábrica. Al probar el equipo del mercado de accesorios, asegúrese de que todo el equipo de fábrica esté conectado antes de encender el llave de encendido.

APLICACIONES (95-2001 OR 99-2001)

BUICK

Century	1997-2005
Le Sabre	1995-2005
Park Avenue	1995-2005
Rainier	2004-2007
Regal.....	1995-2004
Rendezvous.....	2002-2007
Riviera.....	1996-1999
Roadmaster.....	1995-1996
Skylark.....	1996-1998

CADILLAC

Escalade, Escalade ESV & EXT	2003-2006
---------------------------------------	-----------

CHEVROLET

Avalanche.....	2003-2006
Blazer	2002-2005
Cavalier	2000-2005
Colorado	2004-2012
Express Van (full size)	2001-2007

CHEVROLET (CONT)

Impala.....	2000-2005
Kodiak.....	2003-2009
Malibu.....	2001-2003
Malibu Classic.....	2004-2005
Monte Carlo.....	2000-2005
S-10 (con radio ISO DDIN).....	2002-2004
Silverado.....	2003-2006
Silverado Classic.....	2007
Suburban.....	2003-2006
Tahoe.....	2003-2006
Trailblazer.....	2002-2009
Venture.....	2000-2005

GMC

Canyon.....	2004-2012
Envoy.....	2002-2009
Savanna.....	2001-2007

GMC (CONT)

Sierra.....	2003-2006
Sierra Classic	2007
Sonoma (with ISO DDIN radio).....	2002-2004
TopKick.....	2005-2009
Yukon.....	2003-2006

HUMMER

H2.....	2003-2007
---------	-----------

ISUZU

Ascender.....	2003-2008
H-Series.....	2003-2008
I-290/I370.....	2007-2008
I-280/I350.....	2006

OLDSMOBILE

Achieva.....	1996-1998
Alero.....	1999-2004

OLDSMOBILE (CONT)

Aurora.....	1995-2003
Bravada.....	1998-2004
Cutlass.....	1997-1999
Cutlass Supreme.....	1995-1997
Eighty-Eight.....	1994-1999
Intrigue.....	1998-2002
LSS.....	1996-1999
Ninety-Eight.....	1994-1996
Regency.....	1997-1998
Silhouette.....	2000-2004

PONTIAC

Aztec.....	2001-2005
Bonneville.....	2000-2005
Grand Am.....	2001-2005
Montana.....	2000-2005
Sunfire.....	2000-2005

INDICE

Desmontaje del tablero

- Buick Century 1997-2005	4	- Chevrolet Monte Carlo 2000-2005.....	10	- Oldsmobile Achieva 1996-1998.....	15
- Buick Le Sabre 1995-2005.....	4	- Chevrolet S-10 (con radio ISO DDIN) 2002-2004.....	7	- Oldsmobile Alero 1999-2004.....	15
- Buick Park Avenue 1995-2005.....	4	- Chevrolet Silverado/Classic 2003-2007	7	- Oldsmobile Aurora 1995-2003.....	15
- Buick Rainier 2004-2007	13	- Chevrolet Suburban 2003-2006.....	7	- Oldsmobile Bravada 1998-2001.....	7
- Buick Regal 1995-2004.....	4	- Chevrolet Tahoe 2003-2006	7	- Oldsmobile Bravada 2002-2004	13
- Buick Rendezvous 2002-2007	5	- Chevrolet Trailblazer 2002-2009	11	- Oldsmobile Cutlass 1997-1999	16
- Buick Riviera 1996-1999	5	- Chevrolet Venture 2000.....	11	- Oldsmobile Cutlass Supreme 1995-1997	13
- Buick Roadmaster 1995-1996	6	- Chevrolet Venture 2001-2005.....	12	- Oldsmobile Eighty-Eight 1994-1999.....	16
- Buick Skylark 1996-1998.....	6	- GMC Canyon 2004-2008.....	8	- Oldsmobile Intrigue 1998-2002.....	16
- Cadillac Escalade, Escalade ESV & EXT 2003-2006.....	7	- GMC Envoy 2002-2007.....	13	- Oldsmobile LSS 1996-1999	17
- Chevrolet Avalanche 2003-2006.....	7	- GMC Savanna 2001-2002.....	8	- Oldsmobile Ninety-Eight 1994-1996	16
- Chevrolet Blazer 2002-2005	7	- GMC Savanna 2003-2007.....	9	- Oldsmobile Regency 1997-1998	17
- Chevrolet Cavalier 2000-2005.....	8	- GMC Sierra/Classic 2003-2007	7	- Oldsmobile Silhouette 2000.....	11
- Chevrolet Colorado 2004-2008	8	- GMC Sonoma (con radio ISO DDIN) 2002-2004.....	7	- Oldsmobile Silhouette 2001-2004	12
- Chevrolet Express Van (full size) 2001-2002	9	- GMC TopKick 2005-2009	7	- Pontiac Aztec 2001-2005	17
- Chevrolet Express Van (full size) 2003-2007.....	9	- GMC Yukon/Denali/XL 2003-2006.....	7	- Pontiac Bonneville 2000-2005.....	17
- Chevrolet Impala 2000-2005	10	- Hummer H2 2003-2007	14	- Pontiac Grand Am 2001-2005	18
- Chevrolet Kodiak 2003-2009.....	7	- Isuzu Ascender 2003-2005.....	13	- Pontiac Montana 2000 (Except SV6)	11
- Chevrolet Malibu 2001-2003.....	10	- Isuzu H-Series 2003-2008	7	- Pontiac Montana 2001-2005 (Except SV6)	12
- Chevrolet Malibu Classic 2004-2005.....	10	- Isuzu I-290/I370 2007-2008.....	8	- Pontiac Sunfire 2000-2005	18
		- Isuzu I-280/I350 2006	8	Ensamble del kit	19

DESMONTAJE DEL TABLERO 95-2001 OR 99-2001

Buick Century 1997-2005

Buick Regal 1995-2004

1. Quite la pieza de moldura de plástico a la izquierda de la guantera y (1) tornillo Phillips que queda a la vista.
2. Suelte a presión el borde superior del panel del protector de rodillas.
3. Quite (1) tornillo Phillips del panel.
4. Quite el conjunto del cenicero y los (2) tornillos Phillips decada lado.
5. Desenganche todo el bisel de la moldura del tablero y quite.
6. Abra las puertas y suelte las tapas de los extremos de cada lado del tablero.
7. Suelte y quite el panel del radio/conjunto de instrumentos.
8. Quite los (3) tornillos para retirar el radio.

Continúe con el ensamble del kit

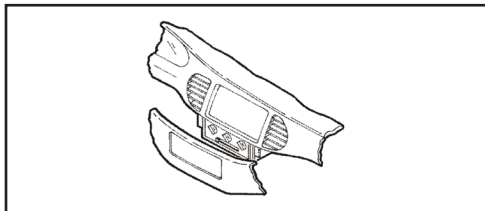

(Figura A)

Buick Le Sabre/Buick Park Avenue 1995-1999

1. Suelte a presión el panel de la moldura del control de clima (de puerta a puerta) y quite los (4) tornillos Phillips expuestos. (Figura A)
2. Saque a presión las rejillas del aire acondicionado y quite (1) tornillo Phillips expuesto en cada cavidad de la rejilla. (Figura A)
3. Desenganche el bisel de la moldura del radio y quite.
4. Quite los tornillos que sujetan la unidad central de fábrica y desconecte el cableado.

Continúe con el ensamble del kit

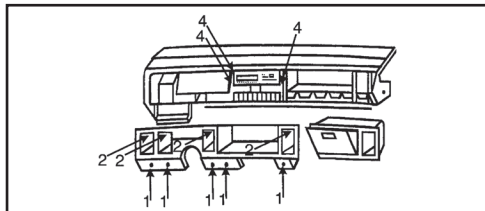

(Figura A)

Buick Le Sabre/Buick Park Avenue 2000-2005

1. Abra la puerta del conductor y suelte a presión y quite la tapa del extremo del tablero.
2. Suelte a presión y retire la moldura a lo largo del centro del tablero (una pieza a la derecha y una a la izquierda del volante).
3. Suelte y retire el bisel del radio/instrumentos.
4. Quite los (2) tornillos para retirar el radio.

Nota: Para el Buick LeSabre, (3) tendrá que ser suministrado clips de velocidad y tornillos para fijar el kit en el sub-tablero donde los orificios de los tornillos se alineen con el kit.

Continúe con el ensamble del kit

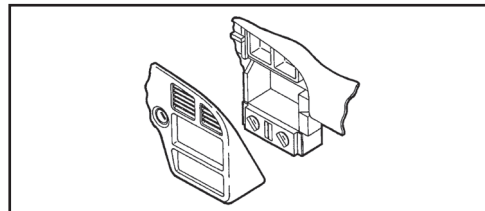

(Figura A)

DESMONTAJE DEL TABLERO 95-2001 OR 99-2001

Buick Rendezvous 2002-2007

1. Abra la consola central y retire los (2) tornillos al frente de la apertura de la consola. (Figura A)
2. Quite los revestimientos de los portavasos y de la cavidad de almacenamiento junto a los portavasos, luego quite los tornillos. Suelte y quite el panel. (Figura B)
3. Quite (2) tornillos de la parte inferior del bisel del radio/control de clima. (Figura C)
4. Quite los (3) tornillos de cabeza hexagonal de 9/32" para quitar el radio. (Figura D)

Continúe con el ensamble del kit

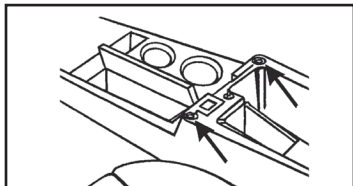

(Figura A)

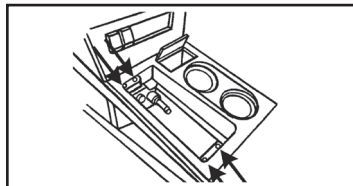

(Figura B)

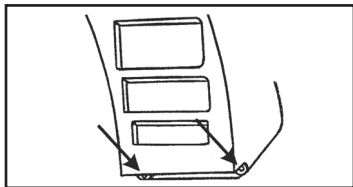

(Figura C)

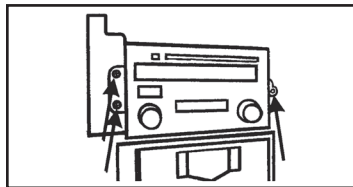

(Figura D)

Buick Riviera 1996-1999

1. Suelte a presión el panel del lado izquierdo, exponiendo (1) tornillo Phillips debajo del panel para retirar.
2. Quite (1) tornillo Phillips y suelte a presión el panel del lado derecho para exponer (1) tornillo Phillips debajo del panel y quite.
3. Suelte a presión la parte inferior del tablero que sobresale para soltar los (6) remaches de plástico y retire el panel.
4. Quite los (5) tornillos de cabeza hexagonal expuestos debajo de la parte que sobresale.
5. Suelte a presión el borde inferior del bisel de la moldura y luego, mientras sostiene la parte que sobresale, suelte y quite el bisel de la moldura, retirando cualquier arnés necesario.
6. Quite los (3) tornillos Phillips para retirar el control de clima.
7. Quite los (2) tornillos Phillips para retirar el soporte posterior y (3) tornillos de cabeza hexagonal de 9/32" para retirar el radio.

Continúe con el ensamble del kit

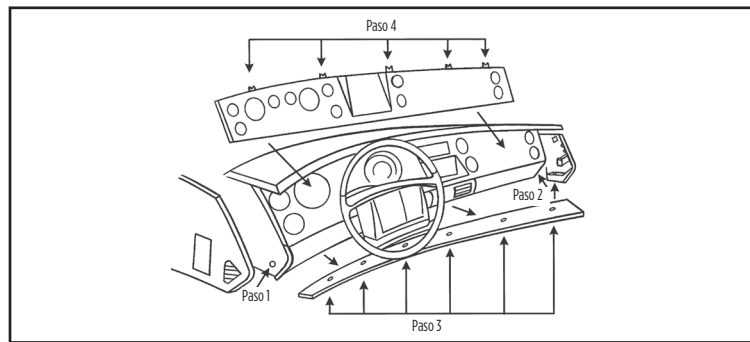

(Figura A)

DESMONTAJE DEL TABLERO 95-2001 OR 99-2001

Buick Roadmaster 1995-1996

1. Desenganche los lados del panel del tablero y quite.
2. Desenganche el panel debajo de la columna de dirección y quite.
3. Quite los (2) tornillos de 7mm de arriba del conjunto de instrumentos.
4. Ponga el freno de mano, encienda el vehículo y mueva la palanca de velocidades al cambio más bajo. Incline el volante hacia abajo, luego suelte a presión todo el panel del conjunto de instrumentos/radio y quite.
5. Quite los (3) tornillos de 7mm para retirar el radio.

Continúe con el ensamble del kit

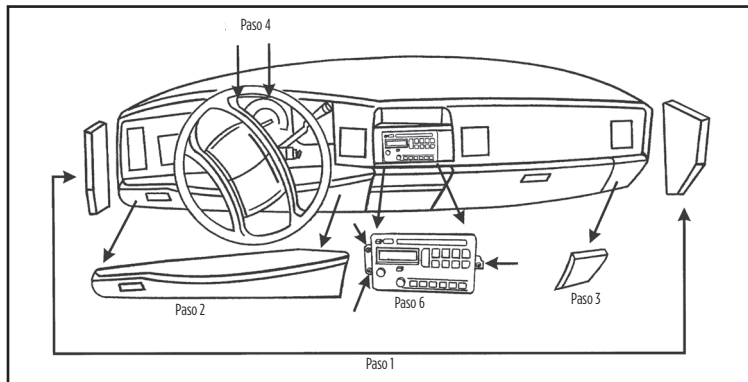

(Figura A)

Buick Skylark 1996-1998

1. Quite los (6) tornillos de 9/32" del interior de la guantera.
2. Debajo de la guantera y del protector de rodillas del conductor, quite (2) paneles de plástico girando los (2) sujetadores 1/4 de vuelta por lado.
3. Quite los (4) tornillos de 9/32" que quedan a la vista (2 por lado).
4. Suelte a presión el panel del lado del conductor al lado del pasajero.
5. Quite (3) tornillos de 9/32".

Continúe con el ensamble del kit

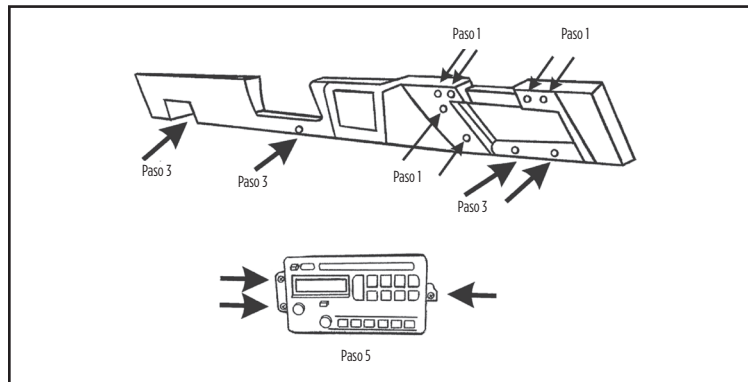

(Figura A)

DESMONTAJE DEL TABLERO 95-2001 OR 99-2001

Cadillac Escalade, Escalade ESV & EXT 2003-2006,
Chevrolet Avalanche/Suburban/Tahoe 2003-2006,
Chevrolet Kodiak 2003-2009,
Chevrolet Silverado/Classic 2003-2007,
GMC Sierra/Classic 2003-2007, GMC TopKick 2003-2009,
GMC Yukon/Denali/XL 2003-2006, Isuzu H-Series 2003-2008

1. Suelte y quite el bisel del tablero.
2. Quite los (3) tornillos de 9/32" y quite el radio.

Continúe con el ensamble del kit

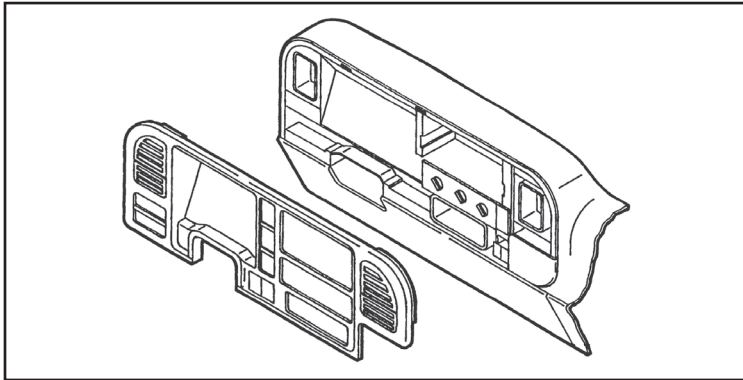

(Figura A)

Chevrolet Blazer 2002-2005,
S-10/GMC Sonoma (con radio de ISO DDIN)) 2002-2004,
Oldsmobile Bravada 1998-2001

1. Quite los (2) tornillos de cabeza hexagonal de 9/32" del panel del protector de rodillas.
2. Jale hacia abajo el panel y quite los tornillos de cabeza hexagonal de 9/32" expuestos en la parte inferior del bisel de la moldura del tablero.
3. Quite (1) tornillo Phillips de arriba del conjunto de instrumentos.
4. Desenganche el bisel de la moldura del tablero y quite.
5. Quite los (2) tornillos de cabeza hexagonal de 9/32" que sujetan la unidad central de fábrica y desconecte el cableado.

Continúe con el ensamble del kit

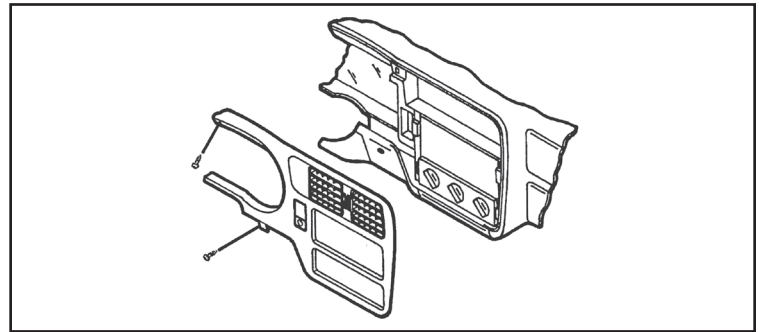

(Figura A)

DESMONTAJE DEL TABLERO 95-2001 OR 99-2001

Chevrolet Cavalier 2000-2005

1. Abra la puerta del conductor y quite el panel de fusibles en el extremo del tablero.
2. Abra la puerta del pasajero y quite el panel del extremo del tablero.
3. Quite (1) tornillo Phillips expuesto de cada lado.
4. Quite los (3) tornillos de la parte superior del revestimiento de la guantera.
5. Quite los (2) tornillos de la esquina superior izquierda de la cavidad de la guantera.
6. Quite (1) tornillo Phillips del conducto del desempañador.
7. Quite el ducto y (1) tornillo Phillips expuesto.
8. Quite la almohadilla del tablero y (3) tornillos Phillips expuestos en la parte superior del bisel de la moldura del radio.

Continúe con el ensamble del kit

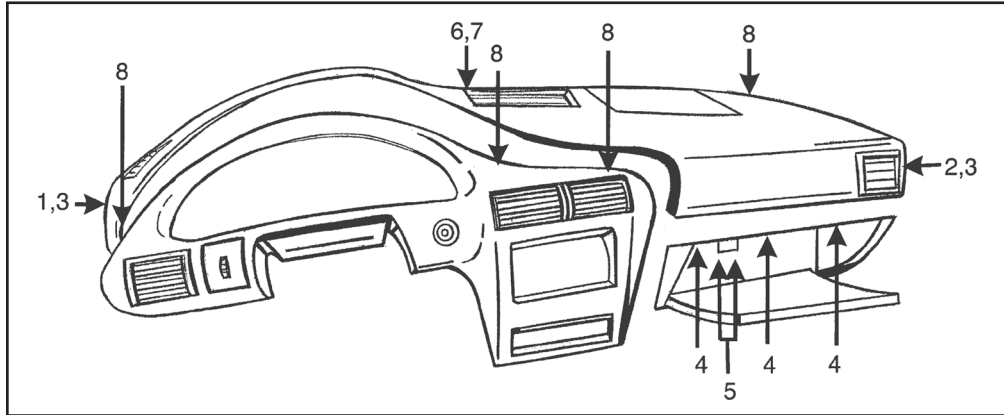

(Figura A)

Chevrolet Colorado 2004-2008, GMC Canyon 2004-2008, Isuzu I-290/I-370 2007-2008, Isuzu I-280/I-350 2006

1. Suelte y quite todo el panel que rodea el radio y los controles del aire acondicionado. (Figura A)
2. Quite los (3) tornillos de 9/32" que sujetan el radio para retirarlo. (Figura B)

Continúe con el ensamble del kit

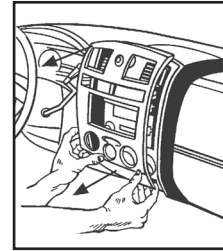

(Figura A)

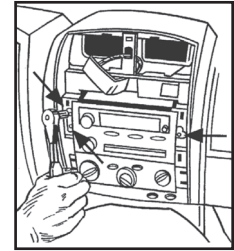

(Figura B)

DESMONTAJE DEL TABLERO 95-2001 OR 99-2001

Chevrolet Express Van 2001-2002, GMC Savanna 2001-2002

1. Suelte a presión y quite el pequeño panel de la moldura debajo de la columna de dirección. (Figura A)
2. Suelte a presión el panel del radio/clima/instrumentos. (Figura B)
3. Mueva la palanca de velocidades a la posición del primer cambio.
4. Gire el panel hacia la izquierda para levantarlo sobre la columna de dirección y quite.
5. Quite los (3) tornillos de cabeza hexagonal de 9/32" para quitar el radio.

Continúe con el ensamble del kit

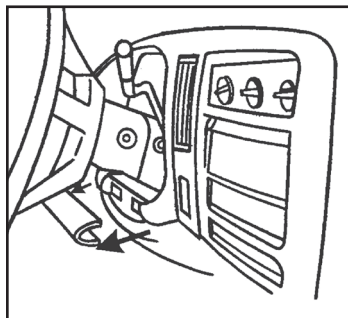

(Figura A)

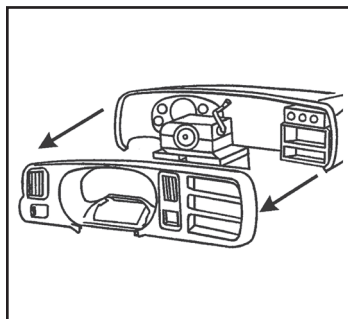

(Figura B)

Chevrolet Express Van 2003-2007, GMC Savanna 2003-2007

1. Quite los (2) pernos de 10mm de abajo del protector de rodillas debajo de la columna de dirección y quite el panel. (Figura A)
2. Quite los (2) pernos de 10mm del panel debajo del de la bolsa de aire del tablero del pasajero y quite el panel. (Figura B)
3. Quite las (2) tuercas de 10mm de la cavidad central interior entre los tomacorrientes. (Figura C)
4. Suelte y quite el panel del radio y conjunto de instrumentos (quizá no sea necesario retirar el radio y el panel del conjunto de instrumentos para obtener acceso al radio).
5. Quite los (3) pernos de 9/32" para quitar el radio.

Continúe con el ensamble del kit

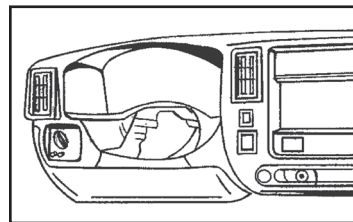

(Figura A)

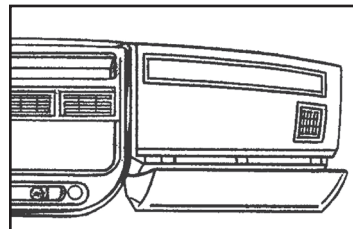

(Figura B)

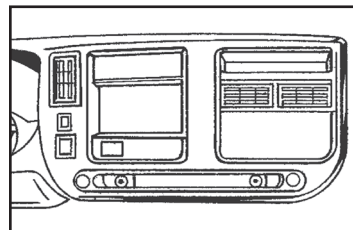

(Figura C)

DESMONTAJE DEL TABLERO 95-2001 OR 99-2001

Chevrolet Impala 2000-2005

1. Desenganche cada lado del bisel de la moldura del tablero (acceso a los fusibles) y quite (1) tornillo Phillips expuesto a cada lado.
2. Quite (2) tornillos Phillips de abajo del conjunto de instrumentos.
3. Desenganche el panel de la moldura sobre los pedales (no es necesario retirar el panel, puede dejarse colgando).
4. Quite los (2) tornillos Phillips del panel para las rodillas.
5. Desenganche el panel para las rodillas y quite (1) tornillo Phillips expuesto en el lado derecho de la columna de dirección.
6. Desenganche y quite todo el bisel de la moldura del tablero.

Continúe con el ensamble del kit

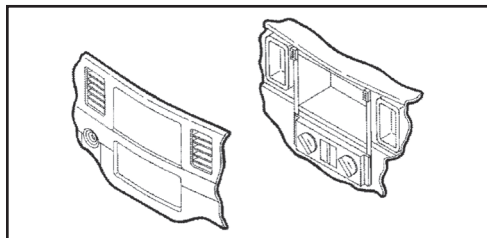

(Figura A)

Chevrolet Malibu 2001-2003, Chevrolet Malibu Classic 2004-2005

1. Suelte y quite el bisel del radio.
2. Quite los (3) pernos y quite el radio.

Continúe con el ensamble del kit

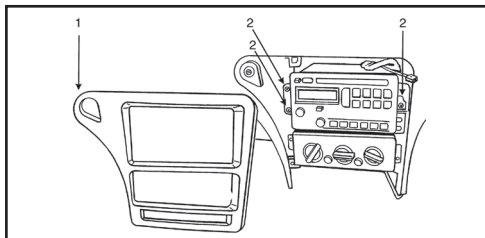

(Figura A)

Chevrolet Monte Carlo 2000-2005

1. Desenganche el panel de la moldura sobre los pedales (no es necesario retirar el panel, puede dejarse colgando).
2. Quite los (2) tornillos de 9/32" del panel para las rodillas y desenganche el panel.
3. Suelte a presión la cubierta del panel de fusibles del lado del conductor y quite (1) tornillo de 9/32".
4. Abra la guantera y quite (1) tornillo de 9/32" de la esquina superior izquierda.
5. Quite los (3) tornillos de 9/32" que sujetan la unidad central de fábrica y desconecte el cableado.

Continúe con el ensamble del kit

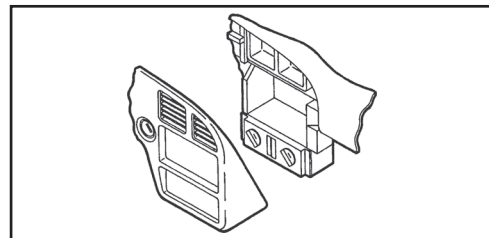

(Figura A)

DESMONTAJE DEL TABLERO 95-2001 OR 99-2001

Chevrolet Trailblazer 2002-2009

1. Quite los (2) tornillos Phillips del interior del conjunto de instrumentos.
2. Quite (1) tornillo Phillips debajo de los controles del clima a la izquierda del tomacorriente.
3. Quite los (2) tornillos de cabeza hexagonal de 7mm debajo de la columna de dirección y baje el panel. Quite los (3) tornillos Phillips de alrededor del volante.
4. Suelte y quite el radio. (Tenga cuidado al jalar sobre el interruptor de las luces intermitentes.) Quite los (3) tornillos de cabeza hexagonal de 7mm para retirar el radio.

Continúe con el ensamble del kit

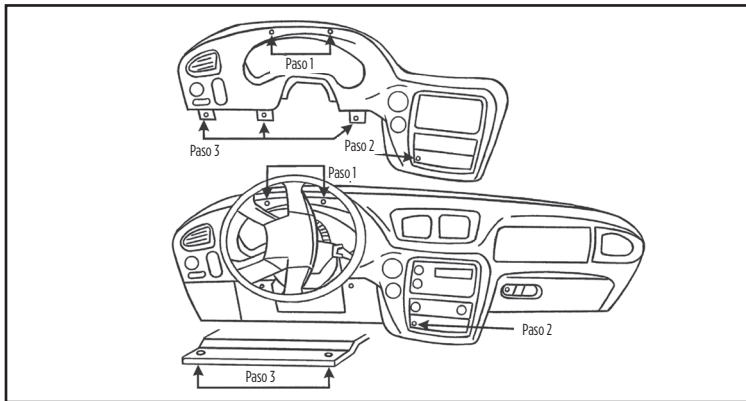

(Figura A)

Chevrolet Venture 2000, Oldsmobile Silhouette 2000, Pontiac Montana 2000 (Except SV6)

1. Quite el encicero y (1) tornillo Phillips expuesto en la cavidad del encicero.
2. Quite (1) tornillo Phillips del compartimiento del encendedor.
3. Quite los (2) tornillos Phillips que sujetan la unidad central de fábrica y desconecte el cableado.

Continúe con el ensamble del kit

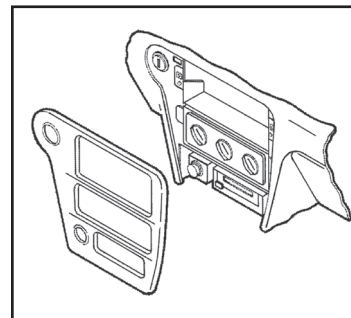

(Figura A)

DESMONTAJE DEL TABLERO 95-2001 OR 99-2001

**Chevrolet Venture 2001-2005,
Oldsmobile Silhouette,
2001-2004 Pontiac Montana 2001-2005**
(Excepto SV6))

1. Abra los portavasos y quite los (2) tornillos Phillips de 7mm. (Figura A)
2. Suelte a presión y quite el conjunto de tomacorriente dual del compartimiento inferior de almacenamiento.
3. Abra la puerta inferior de almacenamiento y quite los (2) tornillos de 7 mm que hay adentro.
4. Modelos con DVD - Quite el reproductor de DVD y quite los (2) tornillos de 7mm de atrás y los (2) tornillos de 7mm cerca del piso.
5. Quite el compartimiento de almacenamiento inferior. (Figura B)

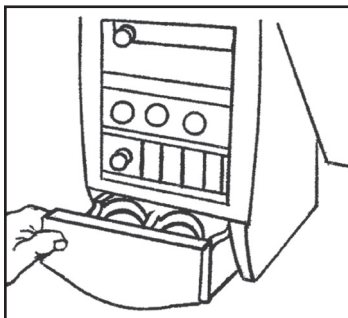

(Figura A)

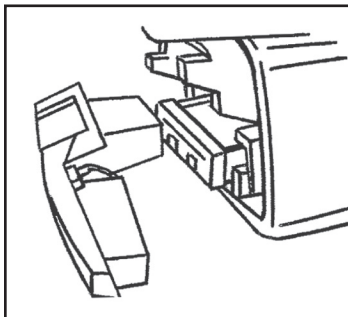

(Figura B)

6. Quite los (2) tornillos de 7mm (orientados hacia arriba) de abajo del portavasos. (Figura C)
7. Quite los (3) tornillos de cabeza hexagonal de 7mm y quite el radio. (Figura D)

Continúe con el ensamble del kit

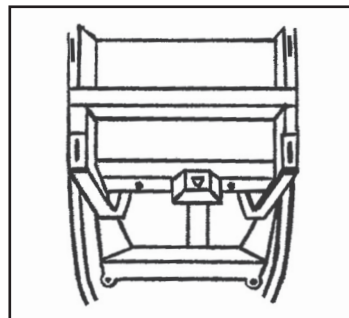

(Figura C)

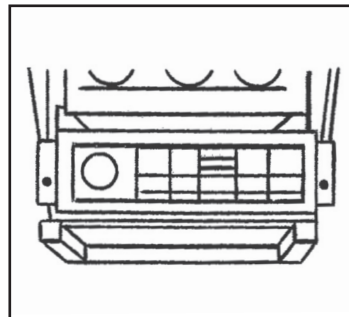

(Figura D)

DESMONTAJE DEL TABLERO 95-2001 OR 99-2001

**GMC Envoy 2002-2007,
Isuzu Ascender 2003-2005,
Oldsmobile Bravada 2002-2004,
Buick Ranier 2004-2007**

1. Quite los (4) tornillos Phillips, (2) de la izquierda y (2) de la derecha del panel alfombrado. (Figura A)
2. Deslice el panel alfombrado hacia abajo y hacia atrás para revelar los (2) tornillos Phillips y quite. (Figura B)
3. Suelte a presión el bisel del radio y desconecte el encendedor y los accesorios. (Figura C)
4. Quite los (3) tornillos y quite el radio. (Figura C)

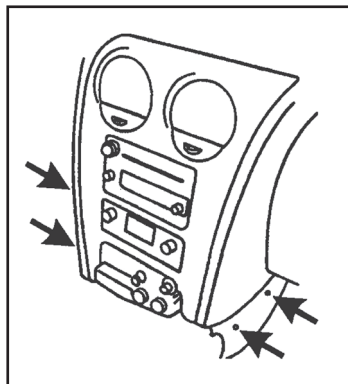

(Figura A)

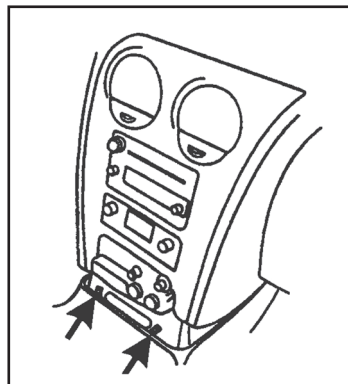

(Figura B)

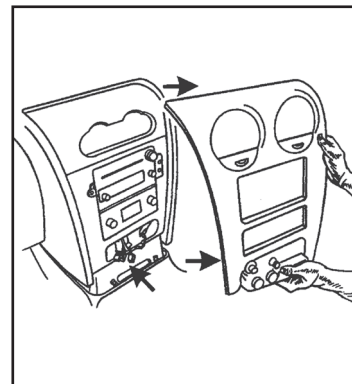

(Figura C)

Continúe con el ensamble del kit

DESMONTAJE DEL TABLERO 95-2001 OR 99-2001

Hummer H2 2003-2007

1. Abra la consola central y quite los (4) tornillos de 9/32" de la caja de la consola y quite la caja. (Figura A)
2. Quite los (4) tornillos Phillips de la bisagra sobre la puerta de la consola al interior de la misma y quite la puerta. (Figura B)
3. Afloje (1) tornillo Torx T-15 en el lado orientado hacia el frente de la palanca de velocidades y jale hacia arriba para retirar. (Figura C)
4. Desenganche el ensamble de la moldura del portavasos/palanca de velocidades y quite. (Figura D)

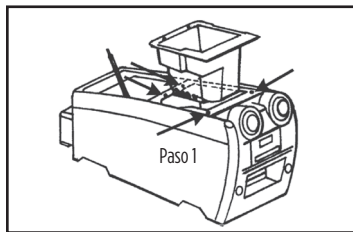

(Figura A)

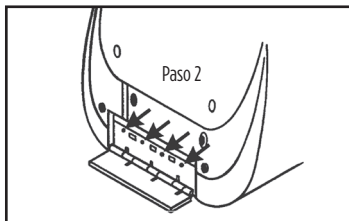

(Figura B)

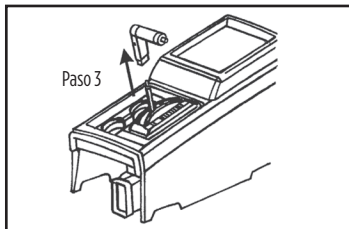

(Figura C)

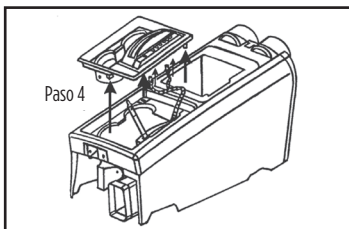

(Figura D)

5. Quite los (6) tornillos Phillips de la parte superior de la consola central. (Figura F)
6. Quite los (2) tornillos Phillips de la cavidad interior en la parte posterior de la consola central, luego desenganche y quite.
7. Retire (1) perno de 10mm a la derecha de la palanca de velocidades. (Figura E)
8. Quite los (2) tornillos Phillips debajo de la caja de la consola del lado del conductor y (2) tornillos Phillips debajo de la parte superior de la moldura de la consola en el lado del pasajero. (Figura F)
9. Deslice el ensamble del control hacia atrás. (Figura F)
10. Quite los (2) pernos Torx T-30 de la parte superior de la moldura del radio/control de clima y desenganche y quite. (Figura G)
11. Quite los (3) tornillos de 9/32" que sostienen el radio dentro. (Figura G)

Continúe con el ensamble del kit

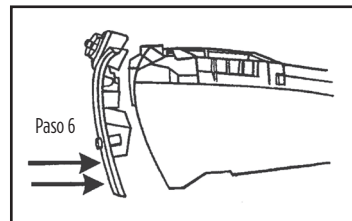

(Figura E)

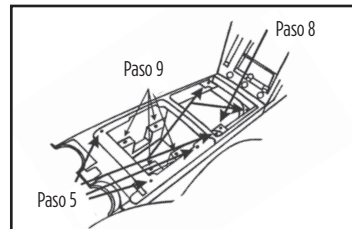

(Figura F)

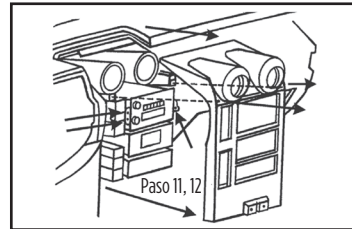

(Figura G)

DESMONTAJE DEL TABLERO 95-2001 OR 99-2001

Oldsmobile Achieva 1996-1998

1. Abra la guantera, presione hacia dentro las paredes del revestimiento de la guantera y quite el revestimiento.
2. Quite los (10) tornillos de cabeza Torx de la guantera.
3. Quite los (2) tornillos de cabeza hexagonal de 9/32" debajo de la columna de dirección.
4. Desenganche el bisel de la moldura del tablero. (Figura A)
5. Quite los tornillos que sujetan la unidad central de fábrica y desconecte el cableado.

Continúe con el ensamble del kit

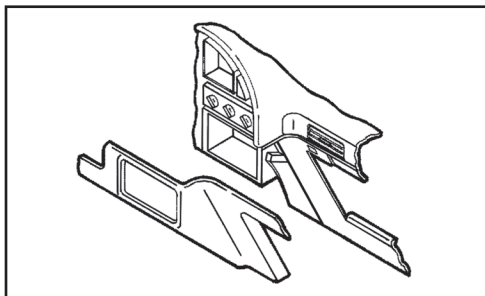

(Figura A)

Oldsmobile Alero 1999-2004

1. Quite la perilla de la palanca de velocidades con un pequeño destornillador para retirar el gancho en U de la parte frontal de la palanca de velocidades y jale hacia arriba.
2. Suelte y quite el panel de moldura de la palanca de velocidades.
3. Desenganche y quite el panel del radio y el control del clima jalando desde abajo. (Figura A)
4. Quite los (3) tornillos de 9/32" del radio y quítelo.

Continúe con el ensamble del kit

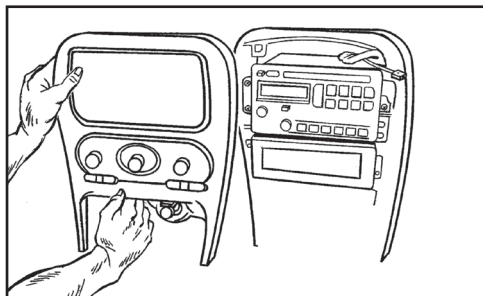

(Figura A)

Oldsmobile Aurora 1995-2003

1. Desenganche el bisel de la moldura del radio y quite el bisel. (Figura A)
2. Retire los (2) tornillos de 7mm que sujetan la unidad central de fábrica y desconecte el cableado.

Nota: Para los modelos 2001-2003, (3) tendrá que ser suministrado clips de velocidad y tornillos para fijar el kit en el sub-tablero donde los orificios de los tornillos se alineen con el kit.

Continúe con el ensamble del kit

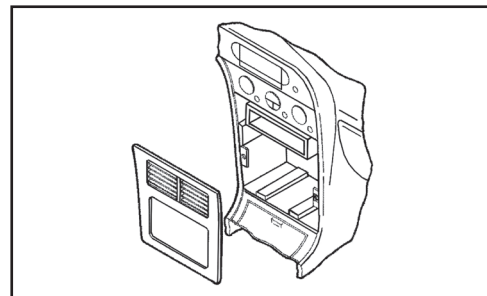

(Figura A)

DESMONTAJE DEL TABLERO 95-2001 OR 99-2001

Oldsmobile Cutlass 1997-1999, Oldsmobile Cutlass Supreme 1995-1997

1. Desenganche el bisel de la moldura del radio y quite. (Figura A)
2. Quite los (2) tornillos de cabeza hexagonal de 9/32" que sujetan la unidad central de fábrica y desconecte el cableado.

Continúe con el ensamble del kit

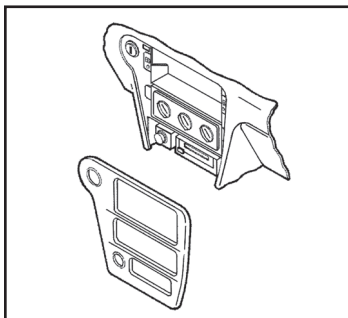

(Figura A)

Oldsmobile Eighty-Eight 1994-1999

1. Desenganche el bisel de la moldura del aradio y quite.
2. Quite los (2) tornillos de cabeza hexagonal de 9/32" que sujetan la unidad central de fábrica y desconecte el cableado.

Continúe con el ensamble del kit

Oldsmobile Ninety-Eight 1994-1996

1. Abra la guantera y retire (2) tornillos de cabeza hexagonal que sujetan la terminación de madera.
2. Quite a presión la terminación de madera y retírela.
3. Retire (2) tornillos de cabeza hexagonal de 9/32 in que se encuentran debajo del marco de terminación del radio.
4. Eleve el marco y retírela.
5. Retire (3) tornillos de cabeza hexagonal de 9/32 in que sujetan la unidad central de fábrica y desconecte el cableado.

Continúe con el ensamble del kit

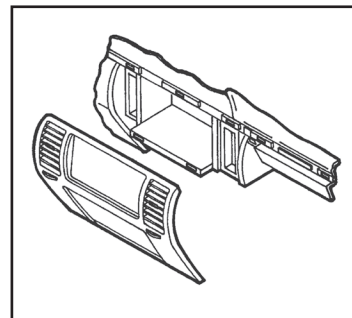

(Figura A)

Oldsmobile Intrigue 1998-2002

1. Abra el compartimiento de almacenamiento de la consola central y quite los (2) tornillos de cabeza hexagonal de 9/32" expuestos.
2. Quite la consola central.
3. Desenganche el bisel de la moldura del radio y quite.
4. Quite los (2) tornillos de cabeza hexagonal de 9/32" que sujetan la unidad central de fábrica y desconecte el cableado.

Continúe con el ensamble del kit

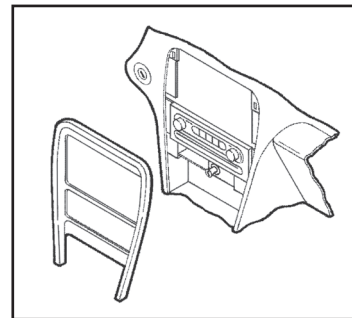

(Figura A)

DESMONTAJE DEL TABLERO 95-2001 OR 99-2001

Oldsmobile LSS 1996-1999 / Regency 1997-1998

1. Abra la guantera y quite dos biseles de moldura centrales unidos con tornillos. (Figura A)
2. Suelte y quite el bisel de la moldura del radio. (Figura A)
3. Quite los (3) tornillos de cabeza hexagonal de 9/32" y quite el radio. (Figura B)

Continúe con el ensamble del kit

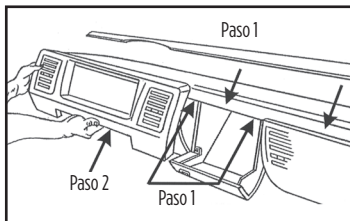

(Figura A)

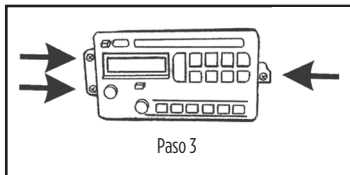

(Figura B)

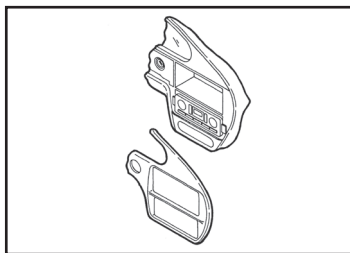

(Figura A)

Pontiac Aztec 2001-2005

1. Jale y saque los insertos de los portavasos.
2. Quite (1) tornillo Phillips expuesto del interior del portavasos.
3. Suelte a presión y quite la moldura de la palanca de velocidades con los portavasos.
4. Quite los (2) tornillos Torx #15 de la parte inferior del bisel del radio/clima.

Continúe con el ensamble del kit

Pontiac Bonneville 2000-2005

1. Quite los (2) tornillos Phillips del conjunto de instrumentos. (Figura A)
2. Desenganche la moldura de la ignición y quite. (Figura B)
3. Desenganche el bisel del control de clima/moldura del radio y quite.
4. Apriete los ganchos de resorte a cada lado de la unidad central de fábrica y quite. (Figura C)

Nota: (3) tendrá que ser suministrado clips de velocidad y tornillos para fijar el kit en el sub-tablero donde los orificios de los tornillos se alineen con el kit.

Continúe con el ensamble del kit

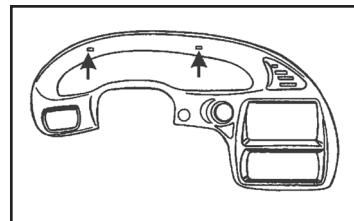

(Figura A)

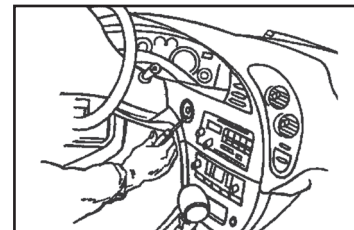

(Figura B)

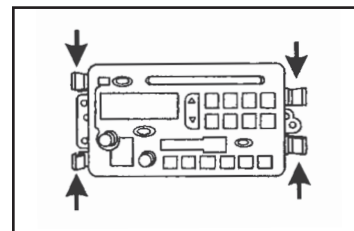

(Figura C)

DESMONTAJE DEL TABLERO 95-2001 OR 99-2001

Pontiac Grand Am 2001-2005

1. Suelte y quite el bisel de la moldura del radio. (Figura A)
2. Quite los (3) tornillos de 9/32" de los soportes del radio y quite el radio. (Figura A)

Continúe con el ensamble del kit

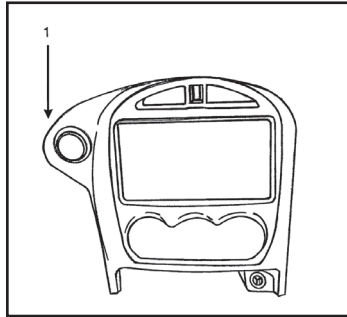

(Figura A)

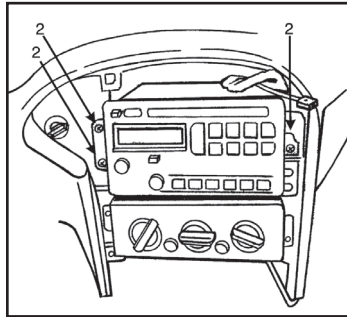

(Figura B)

Pontiac Sunfire 2000-2005

1. Abra la guantera y quite (2) tornillos Phillips expuestos en el borde superior derecho del bisel de la moldura del radio.
2. Desenganche el bisel y quite.
3. Quite los (2) tornillos de cabeza hexagonal de 7 mm que sujetan la unidad central de fábrica y desconecte el cableado.

Continúe con el ensamble del kit

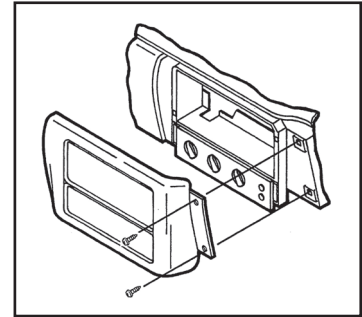

(Figura A)

ENSAMBLE DEL KIT

Provisión de radio ISO DDIN (95-2001):

1. Fije los **soportes de radio** al borde interior de la **placa de moldura del radio**. (Figura A)
2. Deslice el radio en el ensamble terminado y sujételo con los tornillos suministrados con el radio. (Figura B)
3. Localice el arnés de cableado de fábrica y el conector de la antena en el tablero y haga todas las conexiones necesarias al radio. Metra recomienda que use adaptadores adecuados de acoplamiento de Metra y/o de AXXESS. Pruebe el radio para verificar que funcione correctamente.
4. Vuelva a armar el tablero en orden inverso al desmontaje para completar la instalación.

Nota: Los espaciadores incluidos en el kit pueden ser necesarios para adaptarse a las ligeras diferencias de un vehículo a otro. Si el conjunto kit / radio no se encuentra en la parte trasera de la abertura de la radio de fábrica, utilice los espaciadores para eliminar ese espacio.

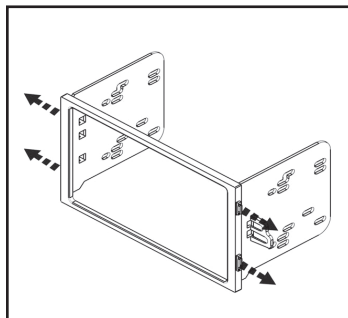

(Figura A)

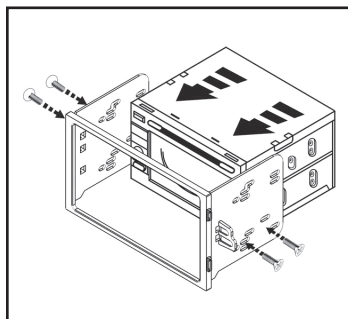

(Figura B)

Provisión de radio ISO DIN con cavidad (99-2001):

1. Fije los **soportes de radio** al borde interior de la **placa de moldura del radio**. (Figura A)
2. Deslice el **cavidad** en el ensamble, y luego asegúrelo usando los (4) tornillos Phillips de # 8 x 3/8 "suministrados. (Figura B)
3. Quite la manga de metal DIN y el anillo de moldura del radio de mercado secundario.
4. Deslice el radio en el soportes/cavidad ensamble terminado y sujételo al ensamble con los tornillos suministrados con el radio. (Figura B)
5. Localice el arnés de cableado de fábrica y el conector de la antena en el tablero y haga todas las conexiones necesarias al radio. Metra recomienda que use adaptadores adecuados de acoplamiento de Metra y/o de AXXESS. Pruebe el radio para verificar que funcione correctamente.
6. Vuelva a armar el tablero en orden inverso al desmontaje para completar la instalación.

Nota: Los espaciadores incluidos en el kit pueden ser necesarios para adaptarse a las ligeras diferencias de un vehículo a otro. Si el conjunto kit / radio no se encuentra en la parte trasera de la abertura de la radio de fábrica, utilice los espaciadores para eliminar ese espacio.

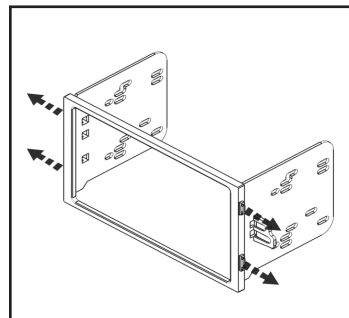

(Figura A)

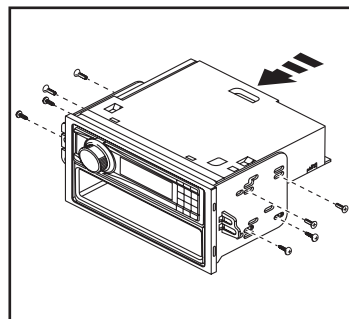

(Figura B)



INST-2001

INSTRUCCIONES DE INSTALACIÓN



¿Tienes dificultades? Estamos aquí para ayudar.



Póngase en contacto con nuestra línea de soporte técnico en:
386-257-1187



O por correo electrónico a:
techsupport@metra-autosound.com

Horas de soporte técnico (hora estándar del este)

Monday - Friday: 9:00 AM - 7:00 PM

Saturday: 10:00 AM - 7:00 PM

Sunday: 10:00 AM - 4:00 PM



KNOWLEDGE IS POWER

Enhance your installation and fabrication skills by enrolling in the most recognized and respected mobile electronics school in our industry. Log onto www.installerinstitute.edu or call 386-672-5771 for more information and take steps toward a better tomorrow.



**Metra recomienda MECP
técnicos certificados**