

INSTALLATION INSTRUCTIONS

8964

REV A

FOR: **ADD-A-LEAF**

READ ALL INSTRUCTIONS THOROUGHLY FROM START TO FINISH BEFORE BEGINNING INSTALLATION

IMPORTANT NOTES:

- To contain the potential energy stored in a leaf spring assembly, secure the leaves with two large C-clamps. See illustration 1.
- Some springs will have a factory helper spring consisting of one or more flat or nearly flat leaves installed at the bottom of the leaf pack. Do not install your Add-A-Leaf spring in or below the helper spring assembly.
- Some vehicle manufacturers recommend replacing U-bolts when removed. New U-bolts may not be supplied with your kit and should be purchased separately.
- These instructions use general procedures for installing an Add-A-Leaf. Obtain and review your vehicle's service manual for specific procedures and specifications.

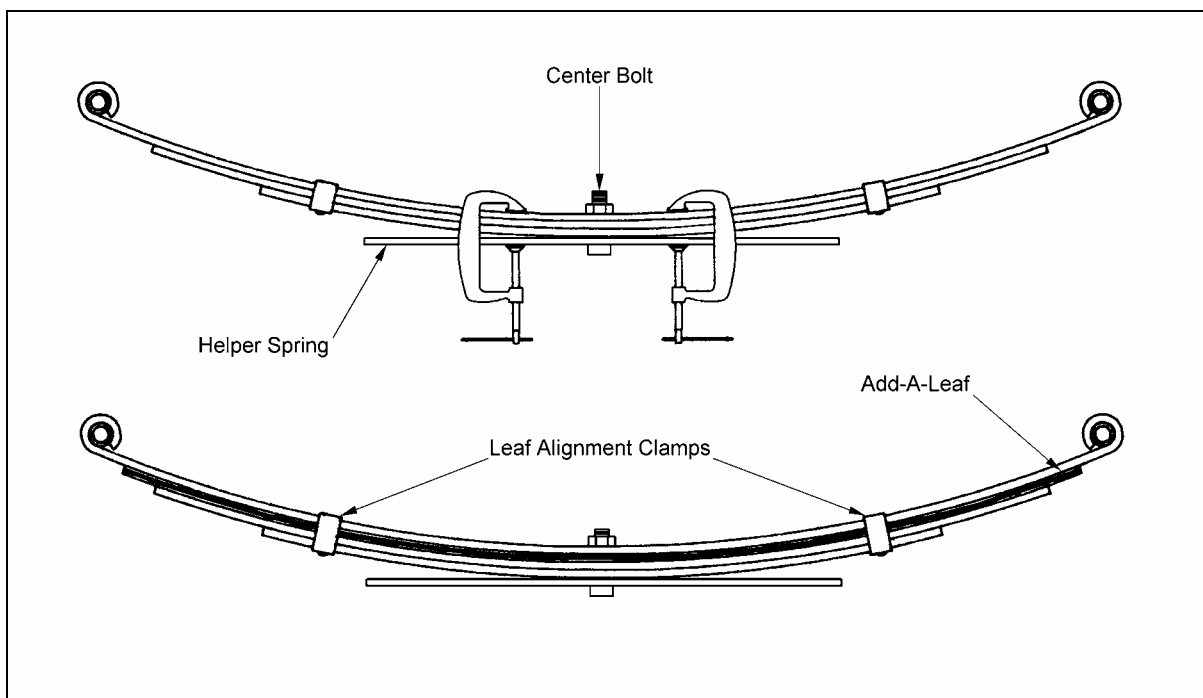

Illustration 1

1. Park the vehicle on a level surface. Set parking brake and chock front wheels. Raise the rear of the vehicle and support the frame with jack stands.
2. Remove the rear wheels.
3. Support the rear axle with a floor jack to relieve the tension on the leaf springs.
4. Remove the rear shock absorbers. Disconnect the axle vent hose from the axle housing.
5. Loosen all the rear axle U-bolt nuts, but do not remove.
6. Remove the left rear axle U-bolts and anchor plate. Remove the spring eye bolts and/or shackles. Carefully lower the rear axle enough to remove the leaf spring from the vehicle. Do not allow the axle to hang from any brake lines or cables.
7. Hold the spring assembly securely together with C-clamps. See illustration 1. If applicable, remove any spring alignment clamps.
8. Remove the center bolt using vise-grips to hold the round head. If the bolt is rusted, it may be necessary to drive the bolt out with a hammer and drift punch.
9. Carefully remove the C-clamps.

Note: Removing and installing one leaf spring assembly at a time will prevent the rear axle from tipping.

10. Apply a small amount of grease to the top ends of the new Add-A-Leaf, and insert it into the leaf pack in a pyramid fashion. Keep the progressive order of longer leaf on top.

11. Reinstall C-clamps on leaf assembly and install a NEW center bolt and nut. Align leaves and tighten center bolt to specifications (20 FT-LBS for 5/16 center bolt, 32 FT-LBS for 3/8 center bolt and 45 FT-LBS for 7/16 center bolt).

Note: It may be necessary to cut off the center bolt if the length is too long.

12. Remove C-clamps and reinstall the spring assembly onto the axle with U-bolts, anchor plate, washers and nuts. Do not tighten at this time.

13. Raise the axle and install the original eye bolts and/or shackles. Do not tighten at this time.

14. Follow steps 5 through 11 for installing the Add-A-Leaf into the right leaf spring assembly.

15. Tighten U-bolt nuts to factory specifications.

16. Reconnect axle vent hose and install shock absorbers.

17. Install the rear wheels and lower the vehicle to the ground. Do not release parking brake or remove wheel chocks.

18. Jounce vehicle to settle springs. Tighten eye bolts and/or shackles to factory specifications.

19. Install the NEW leaf alignment clamps as shown in illustration 2. Apply light pressure to the clamps when installing them and do not bend the tabs of the clamps sharply.

Note: The leaf alignment clamps will prevent lateral shifting or "fanning" of the spring leaves. They are not intended to hold the leaves against one another.

20. Check the vehicle's alignment and adjust headlamps.

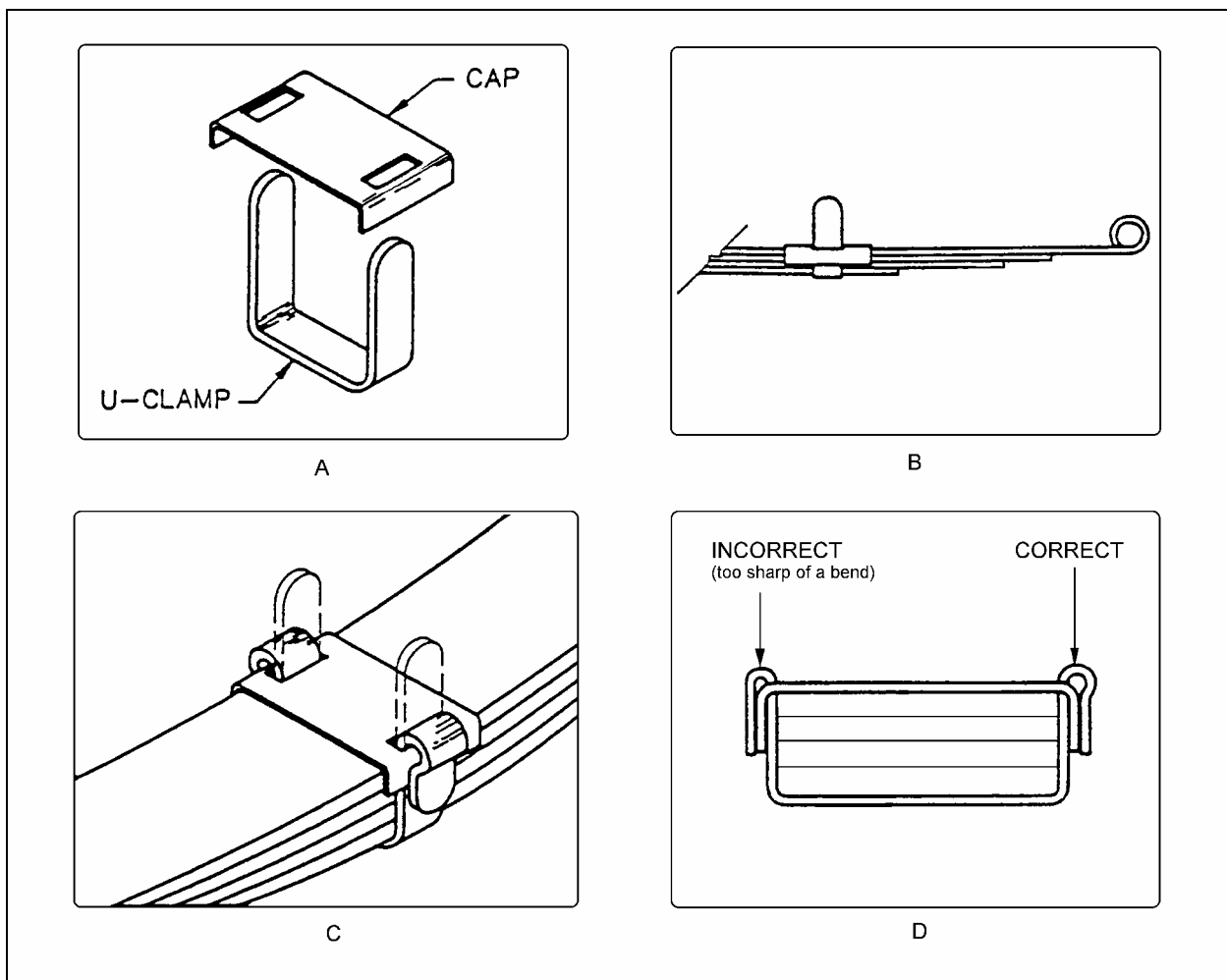

Illustration 2